

---

## List of Contents

<b>1</b>	<b>Introduction</b>	
1.1	Scope and Purpose .....	101
1.2	Meaning of Warnings, Cautions, and Notes .....	101
1.3	Additional Documentation to be used .....	101
1.4	Safety Information and Regulations.....	101
	1.4.1 Legal Provisions for Installation.....	101
	1.4.2 General Safety Notes .....	102
1.5	Corrections and Improvements.....	103
<b>2</b>	<b>General Description</b>	
2.1	Drive .....	201
2.2	Heat Exchanger .....	201
2.3	Control Unit.....	201
2.4	Flame Sensor .....	202
2.5	Glow Plug .....	202
2.6	Temperature Limiter .....	202
2.7	Dosing Pump .....	202
<b>3</b>	<b>Functional Description</b>	
3.1	Controls .....	301
3.2	Switch On .....	301
3.3	Heating Operation.....	301
	3.3.1 Operation with Room Thermostat (mechanical).....	301
	3.3.2 Operation with Switch.....	301
	3.3.3 Operation with Timer .....	301
3.4	Switch Off .....	301
3.5	Ventilation Operation .....	301
<b>4</b>	<b>Technical Data</b>	
4.1	Electrical Components.....	401
<b>5</b>	<b>Troubleshooting</b>	
5.1	General.....	501
5.2	General Fault Symptoms .....	501
<b>6</b>	<b>Functional Checkouts</b>	
6.1	General.....	601
6.2	Adjustments.....	601
	6.2.1 Adjustment of CO <sub>2</sub> Contents .....	601
6.3	Components Testing.....	601
	6.3.1 Temperature Limiter Resistance Check .....	601
	6.3.2 Flame Sensor Resistance Check .....	601

<b>7</b>	<b>Circuit Diagrams and Examples for Electrical Installation</b>	
7.1	General .....	701
<b>8</b>	<b>Servicing</b>	
8.1	General .....	801
8.2	Work on the Air Heater .....	801
8.3	Work on the Vehicle .....	801
8.4	Air Heater Test Run .....	801
8.5	Servicing .....	801
8.6	Visual Inspections and Installation Regulations .....	801
8.6.1	Heating Air System .....	801
8.6.2	Fuel Supply .....	802
8.6.3	Dosing Pump .....	804
8.6.4	Fuel Filter .....	804
8.6.5	Combustion Air Supply .....	805
8.6.6	Exhaust Line .....	805
8.6.7	Combustion Air Intake and Exhaust Lines .....	805
8.7	Removal and Installation .....	806
8.7.1	Heater, Removal and Installation .....	806
8.7.2	Control Unit, Replacement .....	806
8.7.3	Glow Plug, Replacement .....	806
8.7.4	Flame Sensor, Replacement .....	806
8.7.5	Temperature Limiter, Replacement .....	806
8.8	First Operation .....	806
<b>9</b>	<b>Repair</b>	
9.1	General .....	901
9.1.1	Work on Components after Disassembly .....	901
9.2	Disassembly and Assembly .....	902
9.2.1	Control Unit, Replacement .....	902
9.2.2	Glow Plug, Replacement .....	903
9.2.3	Flame Sensor, Replacement .....	903
9.2.4	Temperature Limiter, Replacement .....	903
9.2.5	Drive, Replacement .....	903
9.2.6	Drive, Disassembly and Assembly .....	905
9.2.7	Heat Exchanger, Replacement .....	907
<b>10</b>	<b>Packaging, Storage and Shipping</b>	
10.1	General .....	1001

## List of Figures

301	Functional Diagram.....	302
501	General Failure Symptoms .....	501
701	Operation with Timer and Room Thermostat.....	702
702	Operation with Switch (Full Load - Part Load) and Ventilation .....	703
703	Operation with Room Thermostat (Full Load - Part Load) and Ventilation .....	704
704	Example for Electrical Installation "Operation with Switch and Ventilation" .....	705
705	Example for Electrical Installation "Standard Wiring Harness" .....	706
801	Hot Air Temperatures with Drop of Pressure (12V Heaters).....	802
802	Fuel Supply .....	802
803	Webasto Fuel Tank Tap.....	803
804	Fuel Tapping from Plastic Tank (tapping via fuel drain plug).....	803
805	Fuel Tapping from Plastic Tank (tapping via fitting plate) .....	803
806	Pipe/Hose Connection .....	804
807	Dosing Pump, Installation and Attachment.....	804
808	Fuel Filter.....	804
809	Air Intake Muffler.....	805
810	Exhaust Muffler, Direction of Flow .....	805
811	Exhaust Pipe Outlet, Installation Position .....	805
901	Replacement of Control Unit, Glow Plug, Flame Sensor and Temperature Limiter.....	902
902	Disassembly of Drive .....	904
903	Replacement of Heat Exchanger .....	907

## Your Notes

## 1 Introduction

### 1.1 Scope and Purpose

This repair shop manual is intended to support familiarised personnel in the repair of air heaters HL 90 of the Diesel type.

### 1.2 Meaning of Warnings, Cautions, and Notes

WARNINGS, CAUTIONS, and NOTES in this manual have the following meaning:

#### **WARNING**

This heading is used to highlight that non-compliance with instructions or procedures may cause injuries or lethal accidents to personnel.

#### **CAUTION**

This heading is used to highlight that non-compliance with instructions or procedures may cause damage to equipment.

#### **NOTE**

This heading is used to highlight and draw specific attention to information.

### 1.3 Additional Documentation to be used

This workshop manual contains all information and procedures necessary for the repair of air heaters HL 90. The use of additional documentation is normally not necessary. Operating instructions/ installation instructions and the vehicle specific installation proposal may be used as complementary information as necessary.

### 1.4 Safety Information and Regulations

The general safety regulations for the prevention of accidents and the relevant operating safety instructions have to be observed at all times. "General Safety Regulations" beyond the scope of these regulations are detailed in the following.

The specific safety regulations applicable to this manual are highlighted in the individual chapters by Warnings, Cautions, and Notes.

#### 1.4.1 Legal Provisions for Installation

Within the scope of the StVZO (Road Licensing Regulations of the Federal Republic of Germany) "Design General Approvals", laid down by the Federal Office for Motor Traffic, exist for the Air Heaters HL 90 with the following official marks of conformity:

~ S 269 (Diesel)

The installation of the heaters is to be performed in accordance with the installation instructions and must be checked in case of

- the vehicle type inspection in accordance with § 20 StVZO
- the individual inspection in accordance with § 21 StVZO or
- the examination in accordance with § 19 StVZO performed by an officially authorised expert or examiner for road traffic, a vehicle inspector or a public servant as per section 4 of Annex VIII to the StVZO.

In the event of c) the installation must be certified on the acceptance certificate formsheet included in the copy of the "General Operating License" or on a formsheet according to the specimen of an "approval" included in the Traffic rules 1994, Page 148.

This validates the "Design General Approval". The acceptance certificate must be kept with the vehicle. The year of first operation must be permanently marked on the identification label by removing the numerals of the years not applicable.

**The heat exchanger of the air heater remains serviceable for a maximum of 10 years and must then be replaced with an original spare part by the manufacturer or by one of its authorized workshops. The heater must then be provided with a label marked with the sales date and with the words "Original Spare".**

**When replacing the heat exchanger it is mandatory to also replace the overheat protection element (temperature limiter) to avoid possible malfunctions of old temperature limiters in use.**

**Should exhaust pipes be routed through rooms accommodating persons, these pipes shall also be renewed after 10 years by original spare parts. When removing the heater the gasket below must be renewed.**

The heaters are cleared for heating the passenger and driver cabins but not for heating compartments intended for the transportation of dangerous goods.

The use of the heater in special vehicles (e.g. vehicles for the transportation of dangerous goods ADR) or vehicles not subject to the StVZO (e.g. ships) are ruled by partially regional regulations.

**Heating Air System**

Heating air intake openings must be arranged so that under normal operating conditions exhaust fumes of the vehicle engine or air heater are not likely to be expected.

Extracting combustion air from the vehicle interior is not permissible.

**Combustion Air Line**

The combustion air required must be taken from the exterior.

Within rooms accommodating persons, the combustion air lines must not have more than four disconnects and a splash-water protected exterior wall feedthrough. The disconnects must be sealed in a way not to exceed a leak rate of 200 l/h at an overpressure of 0.5 mbar. The line including feedthrough, disconnects, material and specific type must be described in the installation instructions.

The line must require tools for installation and removal, must be protected against damage, and must be shock-proof.

**Exhaust Line**

Heaters must be designed to discharge the exhaust to the exterior.

Exhaust pipes must be routed so that exhaust fumes are unlikely to penetrate into the vehicle's interior.

The function of any parts of the vehicle essential for its operation must not be impaired. Condensate or water penetrated must not be able to accumulate in the exhaust line.

Drain holes are permissible; these must drain the fluid to the exterior via lines sealed against the vehicle interior.

The exhaust line outlet is to be positioned to the top, to the side, or in case of exhaust venting below the vehicle floor, to the nearest possible location of the vehicle's or cockpit's side or rear end.

In compartments accommodating persons, exhaust lines must not have more than one disconnect and must have a splash-water protected feedthrough in the exterior wall/floor. For water, that has penetrated into the exhaust line, the connection of a drain line with a metal-sealing joint is permissible. The drain pipe must be routed sealed through the exterior wall or the vehicle floor.

The heat exchanger, the exhaust line connected, as well as the possible drain pipe must be sealed so that with an overpressure of double the overpressure of the exhaust having the maximum permissible exhaust line length – at least however at an overpressure of 0.5 bar – a total leak rate of 30 l/h is not exceeded.

The line including feedthrough, disconnects, material and specific type must be described in the installation instructions. The line must require tools for installation and removal, must be protected against damage, and must be shockproof.

Metal lines must be used. These may not heat to more than 110° C should there be the possibility of contact within the room interior. Protective devices against contact may be fitted.

**Combustion Air Inlet and Exhaust Outlet**

During installations these ports for combustion air entry and exhaust fume exit must be of such type, that a ball with a diameter of 16 mm cannot be inserted.

Electrical lines, switch gear and control gear of the heater must be located in the vehicle so that their proper function cannot be impaired under normal operating conditions.

For the routing of fuel lines and the installation of additional fuel tanks §§ 45 and 46 of the StVZO are to be adhered to.

The most important regulations are: Fuel lines are to be designed in such a way that they remain unaffected by torsional stresses in the vehicle, engine movement and the like. They must be protected against mechanical damage.

Fuel-carrying parts are to be protected against excessive heat and are to be arranged so that any dripping or evaporating fuel can neither accumulate nor be ignited by hot components or electrical equipment.

In busses, fuel lines and fuel tanks may be located neither in the passenger area nor in the driver's compartment.

In these type of vehicles the fuel tanks must be located such that they do not pose a direct hazard to the exits in the event of a fire. Fuel supply must not be by means of gravity or pressurization of the fuel tank.

**1.4.2 General Safety Notes**

The heater must not be installed in the passenger or driver compartments of busses. Should the heater nevertheless be installed in such a compartment, the installation box must be sealed tight against the vehicle interior. There must be sufficient ventilation of the installation box from the exterior in order not to exceed a maximum temperature of 40° C in the installation box. Excessive temperatures may cause malfunctions.

The heaters are cleared for heating the passenger and driver cabin in the fresh air mode of operation and for load top compartments in the fresh air or circulation air mode of operation. They are however not cleared for heating loading compartments for dangerous goods. The installation in enclosed areas accommodating persons is not permitted.

If an air heater is installed in a loading compartment for circulation air mode of operation the inside of the entrance door shall be labeled as follows: "With heater on no personnel allowed in loading area with door closed."

The heaters HL 90 are marked with the word "Diesel" on their identification plate. The heaters may only be operated with the specified type of Diesel (or with fuel oil EL) and the appropriate type of electrical installation.

### Installation Instructions for Webasto Fuel Tanks for Fuel Supply of Heaters in Vehicles

In busses the installation is not permitted in the passengers or driver's compartment.

The fuel filler neck must not be located in the passengers or driver's compartment of any type of vehicle. Fuel reservoirs for carburettor fuel must not be located immediately behind the vehicle front fairing. They must be away from the engine to prevent fuel fires in case of accidents.

The same applies to towing vehicles with open cockpit.

It is mandatory to install the seal between the heater mounting and the vehicle floor to prevent poisonous exhaust fumes from entering the vehicle interior.

All fuel line connections must be tight, must show no damage and have to be inspected in regular intervals (at least in the same frequency as vehicle inspections). When detecting damages or leaks the heater must not be operated until repair will have been performed by an authorised Webasto repair shop.

#### NOTE

Make heater inoperative by removing fuse. The fuel lines (Mecanyl hoses) must not be in direct contact with the exhaust pipe and be provided with a heat insulation as required to prevent fires.

Keep air intakes and exit ports for warm and heating air clean and free from foreign objects. Contaminated and clogged air ducts may cause overheating and response of the temperature limiter. After an overheat condition with automatic switch-off check air ducting is free from contamination and remove all objects that might block the airstream or have damage repaired by an authorized Webasto repair shop. Then reset the temperature limiter. Should these corrective actions not cure the problem (overheating occurs again), consult an authorized Webasto repair shop. Never remove the air intake screen upstream of the heater.

The air jets with adjustable flops must always be open in a way that the airflow through the heater is not blocked. A frequently restricted or blocked airflow may cause long time damage. Should a heater be located in a stowage compartment, it must be ensured that no flammable material is stowed in this compartment and that other material does not restrict the air supply of the heater.

**Air lines must be securely fastened to the heater and the air jets (e.g. with pipe clamps).**

Do not step on the heater and do not deposit heavy objects on or throw against the heater.

Do not throw garments, fabrics or similar material on top of the heater or in front of the heating air intake or exit.

The warm air flow of the heater must not be restricted or blocked by easily flammable substances or material like rags, cleaning wool, etc., to prevent fires and smoke.

Flammable or explosive material or gasses must be kept away from the vicinity of the heater, the warm air ducting or the heating airflow.

The heater must not be cleaned with water, fluids or high pressure cleaners, etc.

Do not switch off heater with the battery master switch or the battery emergency off switch to prevent possible long time damage and malfunctions of the heater.

The operating condition of the heater – least on or off – must be clearly visible.

Non-compliance with the installation instructions and its procedures will void the warranty by Webasto. The same applies for repairs performed by unskilled personnel or not using original spare parts. This will also invalidate the official marks of conformity and thus the vehicle's permit of operation.

Make sure to read the operating instructions before you operate the heater.

## 1.5 Corrections and Improvements

Deficiencies, improvements, or proposals for correction of this workshop manual are to be mailed to:

Webasto Thermosysteme GmbH  
Abt. Technische Dokumentation  
D-82131 Stockdorf

Telefon: 0 89 / 8 57 94 - 5 42

Telefax: 0 89 / 8 57 94 - 7 57

## Your Notes

## 2 General Description

The air heater HL90 is used to

- heat the driver compartment and the vehicle interior/passenger compartment
- defrost the windscreen
- heat vehicle loading compartments

The heaters are cleared for heating the passenger compartment and the driver compartment in the fresh air mode of operation of and vehicle loading compartments in the fresh air or circulation air mode of operation. The heating of loading compartments for dangerous goods is not permitted.

The heater operates independent from the vehicle engine and is connected to the vehicle's electrical system and fuel system.

The heaters may be operated in vehicles with water or air-cooled engines.

The heater designed to the rotation atomiser principle operates intermittently controlled by the temperature sensor.

The heater HL90 basically consists of the:

- drive
- heat exchanger

For control and monitoring the heater includes a:

- control unit
- flame sensor
- glow plug
- temperature limiter

Fuel supply is provided externally by a fuel dosing pump.

### 2.1 Drive

The drive provides for fuel supply with atomisation and combustion air supply to the combustion chamber in the heat exchanger.

The drive basically consists of the air intake housing with fuel and combustion air connection, the bypass fan and the atomiser.

The motor is flanged to the air intake housing driving the bypass fan and the atomiser via a clutch. The motor also drives a rotor to suck in fresh air or circulation air across an orifice plate.

Resistors for the glow plug and the motor are also mounted to the air intake housing.

### 2.2 Heat Exchanger

The heat exchanger transfers the heat generated by combustion to the heating air circulated by the fan.

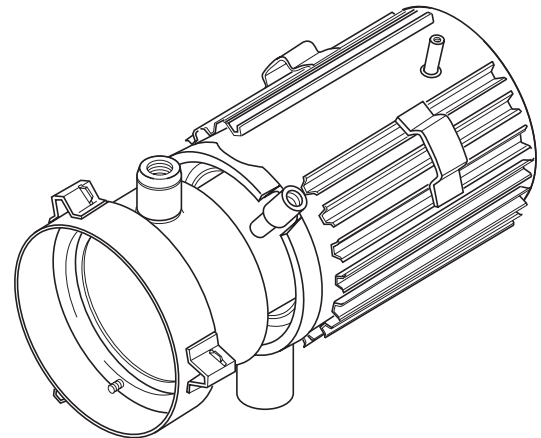

### 2.3 Control Unit

The control unit ensures controlled operation and monitoring of combustion.

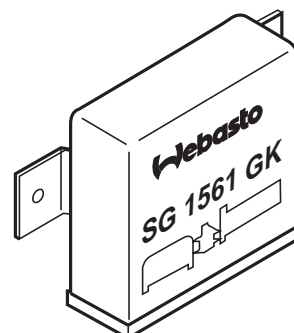

### 2.4 Flame Sensor

The flame sensor is a photo transistor changing its resistance depending on the flame intensity. The signals are supplied to the control unit for processing. The flame sensor continuously monitors the flame condition during heater operation.

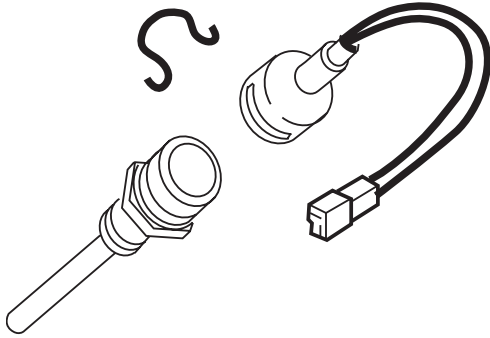

### 2.5 Glow Plug

The glow plug ignites the fuel/air mixture during heater start. The glow plug voltage is 4.2 Volts.

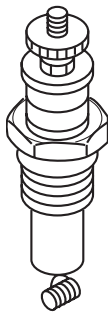

### 2.6 Temperature Limiter

The temperature limiter protects the heater against undue high operating temperatures. The temperature limiter responds at a temperature in excess of 175° C to disconnect the electrical circuit and switch off the heater with a run-down.

After the temperature limiter has cooled down, it may be reset by pressing the reset pin. The heater may then be switched on again.

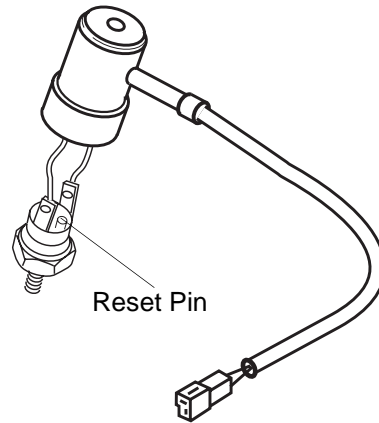

### 2.7 Dosing Pump

The dosing pump is a combined delivery, dosing and shut-off system for the fuel supply of the heater out of the vehicle fuel tank.

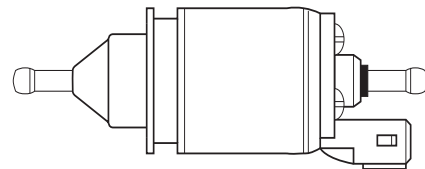

Dosing Pump DP 2

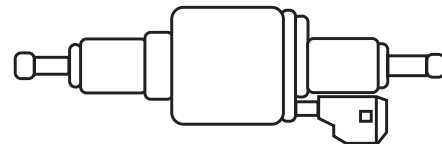

Dosing Pump DP 30

### 3 Functional Description (Fig. 301)

#### 3.1 Controls

The heaters may be equipped with the following controls:

- room thermostat (mechanical)
- switch
- timer

Activation and deactivation is by means of the switch, timer or room thermostat with on/off switch.

An operating indicator light (in timer, switch or room thermostat) indicates the heater on condition.

#### 3.2 Switch On

Upon switch on the operating indicator light goes on and the glow plug is powered. After approximately 35 seconds the fuel dosing pump is put into operation. After another 5 seconds the motor of the heating and combustion air fan is activated. Combustion commences. After flame-up the glow plug is switched off.

If no proper combustion is achieved within 100 seconds, an automatic restart is performed. If the no combustion condition persists, an error lockout will occur within another 80 seconds with a subsequent run-down of 150 seconds.

The operating indicator light remains on in case of an error lockout condition.

#### 3.3 Heating Operation

During operation combustion gasses flow through the heat exchanger to dissipate heat onto the heat exchanger casing from where it is picked up by the heating air flow to the vehicle interior maintained by the heating air fan.

##### 3.3.1 Operation with Room Thermostat (mechanical)

The room thermostat (mechanical) allows selection of full load / part load or part load / off.

- Full load / part load operation  
After reaching the temperature set with the room thermostat (upper switching point of the room thermostat) part load operation will be initiated. When the temperature drops below the lower switching point, the heater resumes full load operation. In part load operation motor speed and dosing pump fuel delivery is reduced.

- Part load / off operation  
After reaching the temperature set with the room thermostat (upper switching point) the heater is switched off. The operating indicator light remains on to indicate a run-down with full speed operation of the heating and combustion air fan motor.  
When the temperature reaches the lower switching threshold of the room thermostat, a new start procedure commences. The heater operates in full load.  
After a short time of full load combustion operation there will be transition to part load operation.

##### 3.3.2 Operation with Switch

During heating operation with a switch manual selection between full load and part load is possible.

##### 3.3.3 Operation with Timer

The timer is used for switch on with a switch (instant heat) or for time preset operation. A control in the operating modes full load / part load may be provided by integration of the room thermostat (mechanical).

#### 3.4 Switch Off

Switching the heater off extinguishes the operating indicator light of the room thermostat, the switch or the timer. Fuel supply is cut off stopping combustion.

The motor of the heating and combustion air fan continues operation to cool the heater down (run-down).

Run-down time: 150 to 190 seconds

Run-down operation is controlled automatically.

#### NOTE

The motor of the heating and combustion air fan always operates in full load during run-down.  
Re-activation of the heater during run-down is permitted.  
Run-down is then completed with a subsequent new start.

#### 3.5 Ventilation Operation

When equipped with a room thermostat ventilation operation is only possible with a separate switch (order no. 109 995 (24V), 109 999 (12V)).

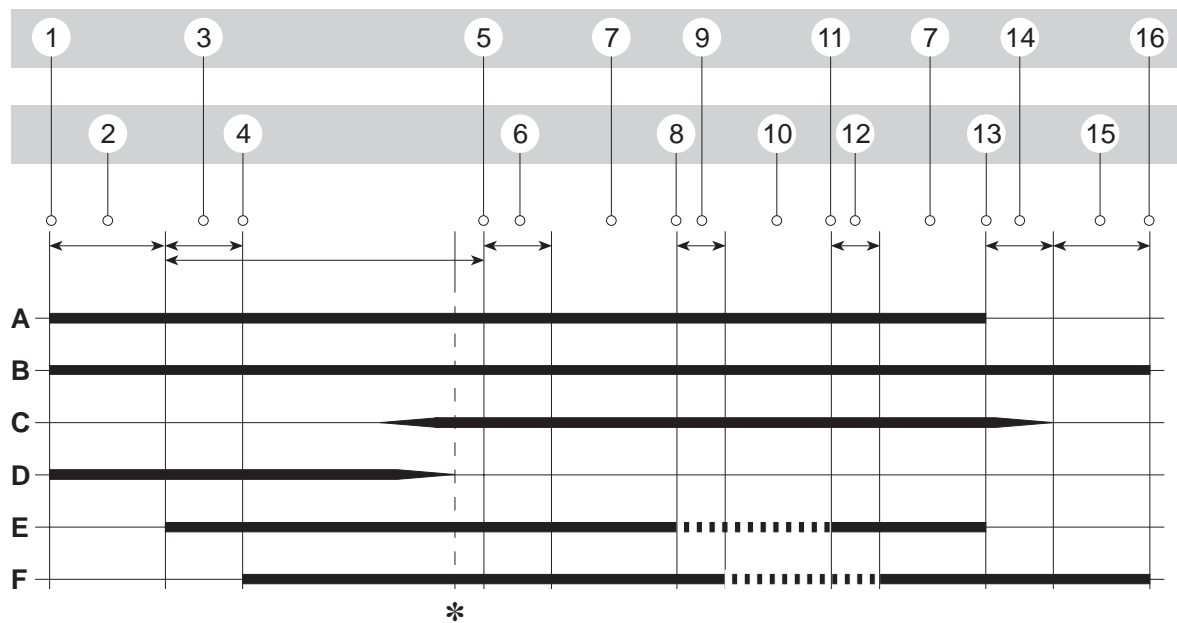

- |   |  |
|---|--|
| ① Switch on                                   | A Operating indicator light on   |
| ② Preheating 35 s                             | B Switch or room thermostat (full load / part load) or timer                                 |
| ③ Fuel priming                                | C Flame sensor   |
| ④ Full load initiation                        | D Glow plug  |
| ⑤ Safety period max. 100 s                    | E Dosing pump (full load / part load)  |
| ⑥ Minimum full load time 60 s                 | F Combustion air fan (full load / part load)   |
| ⑦ Combustion operation – full load            |  |
| ⑧ Room temperature (at rated value)           | * In case of no flame condition automatic repeat start (25 s preheating, 80 s safety period) |
| ⑨ Transition from full load to part load 8 s  |  |
| ⑩ Combustion operation – part load            |  |
| ⑪ Room temperature (below rated value)        |  |
| ⑫ Transition from part load to full load 10 s |  |
| ⑬ Switch off                                  |  |
| ⑭ Optical run-down max. 40 s                  |  |
| ⑮ Electronic run-down 150 s                   |  |
| ⑯ Off   |  |

Fig. 301 Functional Diagram

## 4 Technical Data

Where no threshold values are specified technical data are understood to include standard tolerances for heater units of  $\pm 10\%$  at ambient temperature of  $+20^\circ\text{C}$  and at nominal voltage.

### 4.1 Electrical Components

Control unit, motor, dosing pump, glow plug resistor, part load resistor, timer and switch with indicator light are 12 V or 24 V components.

Temperature limiter, flame sensor and glow plug are identical in 12 V and 24 V heaters.

Glow plug default voltage is 4.2 V  $+0.1/-0.15$  at nominal voltage at control unit input (A1).

Air Heater			HL 90				
Heater type			HL 90				
Type			~ S 269				
Mark of conformity			Air Heater with rotation atomiser				
Heat flow	full load operation	kW	9				
	part load operation	kW	6.5				
Type of fuel			Diesel / Fuel oil EL				
Fuel consumption	full load operation	kg/h (l/h)	1.00 (1.20)				
	part load operation	kg/h (l/h)	0.71 (0.86)				
Nominal voltage			V– 12 or 24				
Operation voltage			V– 10 ... 14.5 or 20.5 ... 29				
Rated power consumption (not in start operation)	full load operation	W	24 V	160	12 V	110	
	part load operation	W		95		85	
Permitted ambient temperature (operation):							
– Heater		$^\circ\text{C}$	–40 ... +50				
– Control unit		$^\circ\text{C}$	–40 ... +85				
– Dosing pump		$^\circ\text{C}$	–40 ... +40				
Permitted ambient temperature (storage):							
– Heater		$^\circ\text{C}$	–40 ... +85				
– Control unit		$^\circ\text{C}$	–40 ... +85				
– Dosing pump		$^\circ\text{C}$	–40 ... +85				
Setting range of indoor temperature			$^\circ\text{C}$ +30 max.				
Volume flow of heating air – against 0.5 mbar	full load operation	$\text{m}^3/\text{h}$	24 V	310	12 V	280	
	part load operation	$\text{m}^3/\text{h}$		215		195	
– against 0.25 mbar							
CO <sub>2</sub> in exhaust – permitted functional range			full load operation	Vol.-%			7 ... 10
CO in exhaust – at no wind				Vol.-%			0.1 max.
– at 100 km/h				Vol.-%			0.2 max.
HC in exhaust at nominal load and no wind				Vol.-%			0.01 (100 ppm) max.
NOx in exhaust at nominal load and no wind				Vol.-%			0.02 (200 ppm) max.
Soot number			– to Bacharach				< 6.0
			– to Bosch				< 0.5
Dimensions heater: (tolerance $\pm 3$ mm)	length	mm	650				
	width	mm	235				
	height	mm	260				
Dimensions dosing pump: (tolerance $\pm 3$ mm)	length	mm	113				
	width	mm	40				
	height	mm	35				
Dimensions control unit 1561: (tolerance $\pm 3$ mm)	length	mm	97				
	width	mm	102				
	height	mm	36				
Weight:	Heater	kg	13				
	Control unit	kg	0.30				
	Dosing pump	kg	0.35				

## Your Notes

## 5 Troubleshooting

### 5.1 General

This section describes troubleshooting procedures for the heater HL90.

**CAUTION**

Troubleshooting requires profound knowledge about components and their theory of operation and may only be performed by trained personnel.

In case of doubt functional interrelations may be derived from Sections 2 and 3.

**CAUTION**

Troubleshooting is normally limited to the isolation of defective components. The following possible causes for trouble have not been taken into consideration and must always be excluded as a possible cause for malfunction:

- check fuel, combustion air and exhaust lines for obstructions
- corrosion on connectors
- loose contacts on connectors
- wrong crimping on connectors
- corrosion on wiring and fuses
- corrosion on battery terminals

For individual component checks the electrical connections on the control unit have to be disconnected.

After any fault correction a functional checkout in the vehicle has to be performed.

### 5.2 General Fault Symptoms

The following table (Fig. 501) lists possible fault symptoms of general nature.

Symptom	Probable Cause	Remedy
Heater switches off automatically	<p>No combustion after start and restart</p> <p>Flame-out during operation</p> <p>Heater overheats Dosing pump does not deliver fuel</p> <p>Vehicle's electrical system voltage too low</p>	<p>Switch off heater momentarily and switch on <u>once</u> again</p> <p>Switch off heater momentarily and switch on <u>once</u> again</p> <p>Check combustion air ducting for obstructions, allow heater to cool down, reset temperature limiter,</p>  <p>Check dosing pump</p> <p>Charge battery</p>
Heater is immediately in run-down	Replace sensor defective	Replace flame sensor
Heater develops black smoke	Combustion air and/or exhaust ducting clogged	Check combustion air and exhaust ducting for obstructions

Fig. 501 General Failure Symptoms

## Your Notes

## **6 Functional Checkouts**

### **6.1 General**

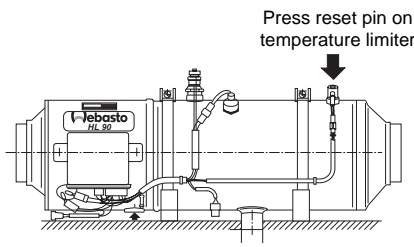
This section describes the tests and adjustments on the heater in installed and removed condition to prove its serviceability.

#### **WARNING**

The heater must not be operated in closed areas like garages or workshops not provided with exhaust ventilation facilities.

### **6.2 Adjustments**

#### **6.2.1 Adjustment of CO<sub>2</sub> Contents**

The HL90 heater does not require a CO<sub>2</sub> adjustment.

### **6.3 Components Testing**

#### **CAUTION**

For individual components checks the electrical connections on the control unit must be disconnected.

#### **6.3.1 Temperature Limiter Resistance Check**

With the reset pin pressed check temperature limiter for electrical continuity.

#### **6.3.2 Flame Sensor Resistance Check**

The check is to be performed with an ohmmeter.

#### **NOTE**

The resistance is to be checked alternately on the connector (reversed polarity).

No light for flame sensor (photo transistor)

- resistance 5 kΩ

## Your Notes

## **7 Circuit Diagrams and Examples for Electrical Installation**

### **7.1 General**

Circuit diagrams (Fig. 701 to 703) show possible heater circuits for HL90 with

- timer and room thermostat
- switch (full load - part load) and ventilation
- room thermostat (full load - part load) and ventilation

Examples (Fig. 704 and 705) show the proper electrical installation for operation with switch and ventilation (Fig. 704) as well as the use of the standard wiring harness (Fig. 705).

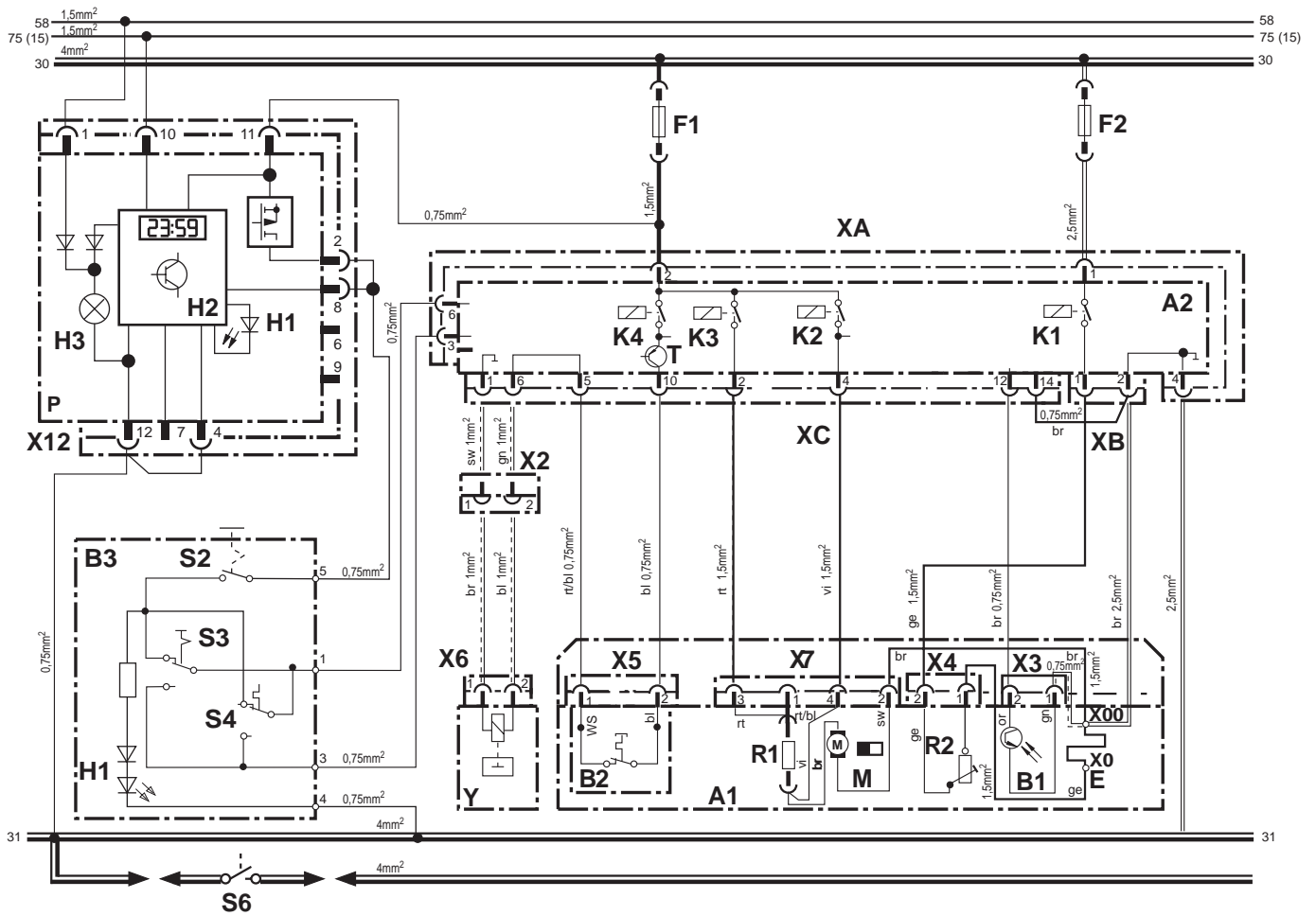

**Wire Colours**

bl	blue
br	brown
ge	yellow
gn	green
gr	grey
or	orange
rt	red
sw	black
vi	violet
ws	white

**Wire Gauges**

	< 7.5 m	7.5 - 15 m
	0.75 mm <sup>2</sup>	1.5 mm <sup>2</sup>
	1.0 mm <sup>2</sup>	1.5 mm <sup>2</sup>
	1.5 mm <sup>2</sup>	2.5 mm <sup>2</sup>
	2.5 mm <sup>2</sup>	4.0 mm <sup>2</sup>
	4.0 mm <sup>2</sup>	6.0 mm <sup>2</sup>

Item	Nomenclature	Remark
Y	Dosing pump	12V
Y	Dosing pump	24V
X12	Connection	12-pole
X7	Connection	4-pole
X6	Connection	2-pole
X5	Connection	2-pole
X4	Connection	2-pole
X3	Connection	2-pole
X2	Connection	2-pole
X1	Connection	1-pole
X0	Clamping connection	Glow plug +
X00	Clamping connection	Glow plug -
XC	Connect. for tab receptacle	14-pole
XB	Connect. for tab receptacle	2-pole
XA	Connect. for tab receptacle	6-pole
T	Transistor	in control unit
S6	Battery switch	in vehicle
S4	Thermostat, heating full load / part load	
S3	Switch, heating full load / part load	

Item	Nomenclature	Remark
S2	Switch, ON/OFF	
R2	Glow plug resistor	12V
R2	Glow plug resistor	24V
R1	Resistor	12V
R1	Resistor	24V
P	Timer (1531)	12V
P	Timer (1531)	24V
M	Motor	12V
M	Motor	24V
K4	Relay	in control unit
K3	Relay	in control unit
K2	Relay	in control unit
K1	Relay	in control unit
H3	Symbol illumination for digital display	
H2	Operating indicator light, heating / ventilation	
H1	Light	Operation indicator
F2	Flat fuse	12V 20A
F2	Flat fuse	24V 20A
F1	Flat fuse	12V 20A

Item	Nomenclature	Remark
F1	Flat fuse	24V 20A
E	Glow plug	4V
B3	Room thermostat	12/24V
B2	Temperature limiter	12/24V
B1	Flame sensor	12/24V
A2	Control unit	12V
A2	Control unit	24V
A1	Heater HL 90	12V
A1	Heater HL 90	24V

Fig. 701 Operation with Timer and Room Thermostat



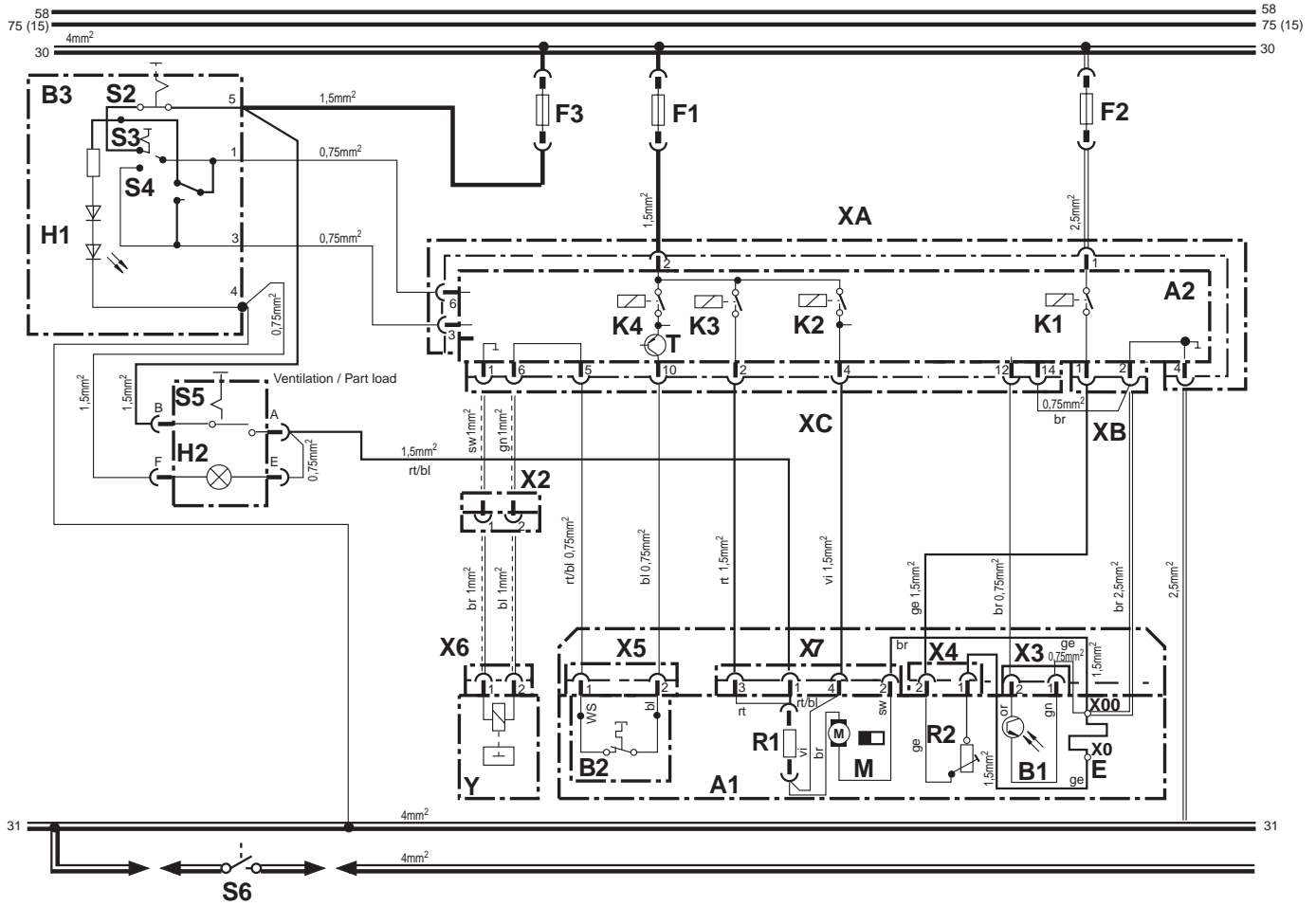

Wire Colours	
bl	blue
br	brown
ge	yellow
gn	green
gr	grey
or	orange
rt	red
sw	black
vi	violet
ws	white

Wire Gauges		
	< 7.5 m	7.5 - 15 m
	0.75 mm <sup>2</sup>	1.5 mm <sup>2</sup>
	1.0 mm <sup>2</sup>	1.5 mm <sup>2</sup>
	1.5 mm <sup>2</sup>	2.5 mm <sup>2</sup>
	2.5 mm <sup>2</sup>	4.0 mm <sup>2</sup>
	4.0 mm <sup>2</sup>	6.0 mm <sup>2</sup>

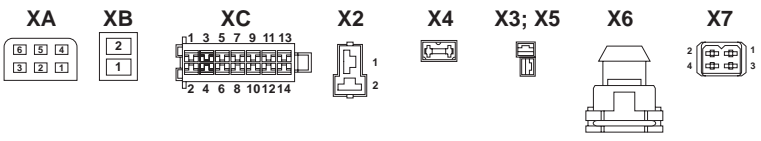

Item	Nomenclature	Remark
Y	Dosing pump	12V
Y	Dosing pump	24V
X7	Connection	4-pole
X6	Connection	2-pole
X5	Connection	2-pole
X4	Connection	2-pole
X3	Connection	2-pole
X2	Connection	2-pole
XC	Connection for tab rectable	14-pole
XB	Connection for tab rectable	2-pole
XA	Connection for tab rectable	6-pole
X0	Clamping connection	Glow plug +
X00	Clamping connection	Glow plug -
T	Transistor	in control unit
S6	Battery switch	in vehicle
S5	Switch, ventilation, full load / part load	12V
S5	Switch, ventilation, full load / part load	24V
S4	Thermostat, heating, full load / part load	
S3	Switch, heating, full load / part load	

Item	Nomenclature	Remark
S2	Switch ON / OFF	
R2	Glow plug resistor	12V
R2	Glow plug resistor	24V
R1	Resistor	12V
R1	Resistor	24V
M	Motor	12V
M	Motor	24V
K4	Relay	in control unit
K3	Relay	in control unit
K2	Relay	in control unit
K1	Relay	in control unit
H2	Operating indicator light, heating / ventilation	12V
H2	Operating indicator light, heating / ventilation	24V
H1	Light	Operation indicator
F3	Flat fuse	12V 10A
F3	Flat fuse	24V 7,5A
F2	Flat fuse	12V 20A

Item	Nomenclature	Remark
F2	Flat fuse	24V 20A
F1	Flat fuse	12V 20A
F1	Flat fuse	24V 20A
E	Glow plug	4V
B3	Room thermostat	12/24V
B2	Temperature limiter	12/24V
B1	Flame sensor	12/24V
A2	Control unit	12V
A2	Control unit	24V
A1	Heater HL 90	12V
A1	Heater HL 90	24V

Fig. 703 Operation with Room Thermostat (Full Load - Part Load) and Ventilation

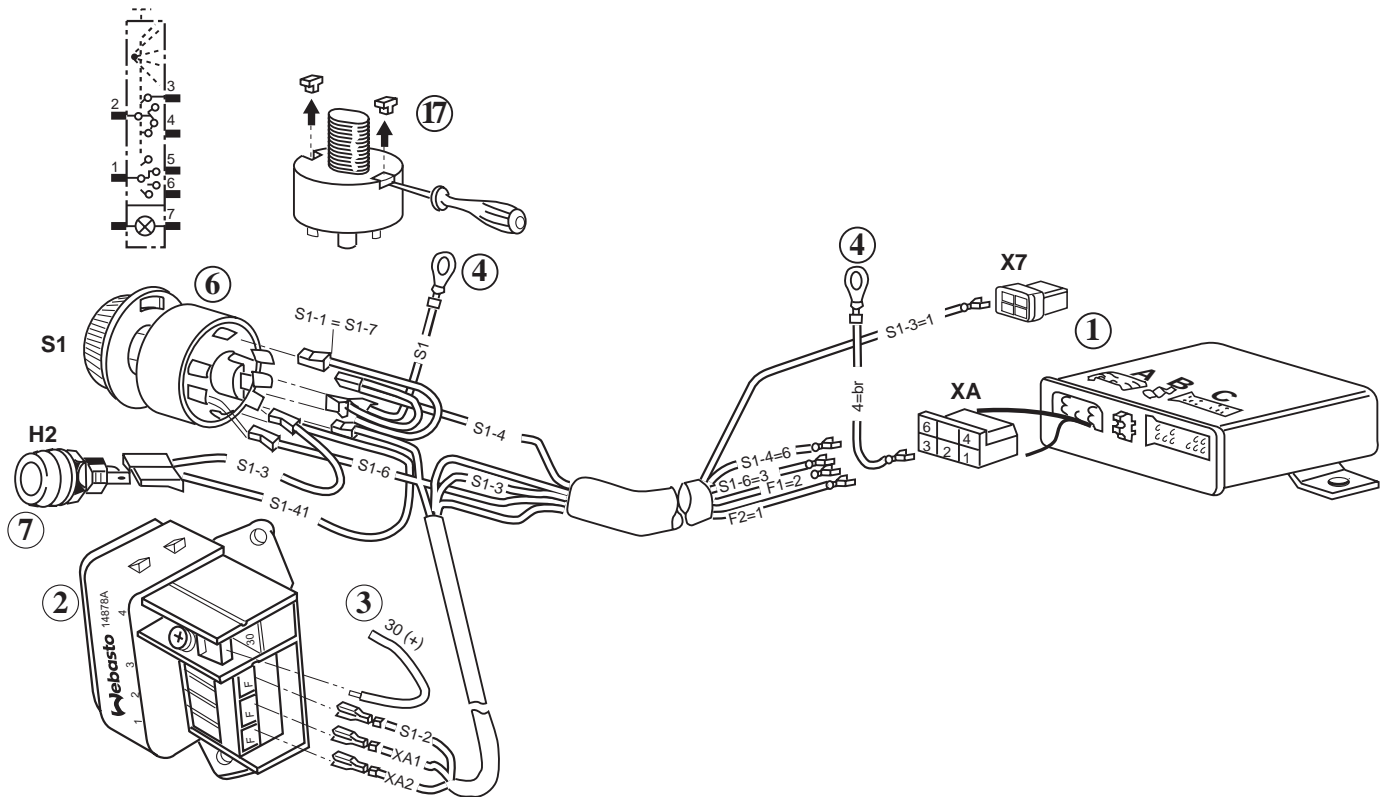

**Connection Control Unit / Fuse Holder / Switch**

- 1 Control unit
- 2 Fuse holder
- 3 to battery (+)
- 4 Ground (-)
- 6 Switch
- 17 Remove two inhibit pins
- 7 Operating indicator light (heating and ventilation)

Fig. 704 Example for Electrical Installation "Operation with Switch and Ventilation"

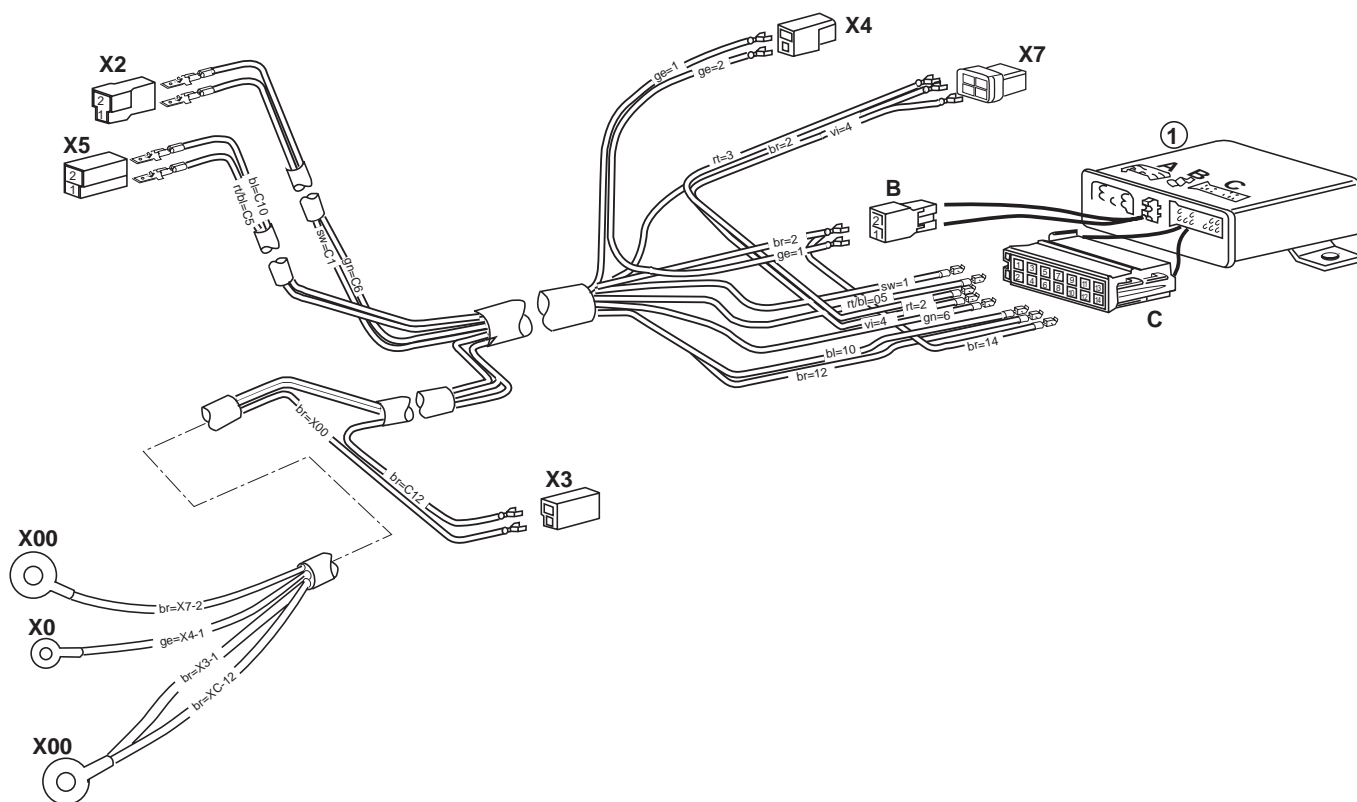

- X2 Intermediary connector dosing pump
- X3 Connector flame sensor
- X4 Connector glow plug resistor
  
- X5 Connector temperature limiter
  
- X7 Connector relay/fuse
  
- X0;  
X00 Connector glow plug
  
- ① Control unit

Fig. 705 Example for Electrical Installation "Standard Wiring Harness"

## 8 Servicing

### 8.1 General

This section describes the servicing procedures allowed on the heater when installed.

### 8.2 Work on the Air Heater

For any type of work on the heater the main power supply cable is to be disconnected from the vehicle battery. As long as the heater is in operation or in run-down the battery main power supply must not be disconnected to prevent the heater from overheating by response of the overheat protection. When performing long time repairs on the heater its removal is considered appropriate.

Repairs requiring a change of location the relevant installation instructions and the vehicle specific heater installation proposal have to be observed.

### 8.3 Work on the Vehicle

#### CAUTION

In the vicinity of the heater a temperature of 85° C must under no circumstances be exceeded (e.g. during paint work on the vehicle).

### 8.4 Air Heater Test Run

#### WARNING

The heater must not be operated, not even with the timer, in enclosed areas like garages or workshops not provided with exhaust ventilation facilities.

## 8.5 Servicing

#### NOTE

In order to avoid seizure of mechanical components, the air heater should be operated every 4 weeks for at least 10 minutes.

The heater does not require maintenance. It should however be checked by Webasto-trained skilled personnel in regular intervals, the latest before the heating season begins (point of time, when the heater is more frequently in use due to weather conditions).

To ensure functional reliability of the heater the following servicing must be performed:

- check combustion air inlet and exhaust outlet for contamination (contaminated and clogged heating air ducts may cause overheating and response of the temperature limiter).
- clean air heater exterior (prevent the ingress of water).
- check clamps for security.
- examine electrical connections for corrosion of contacts and for security.
- check combustion air and exhaust ducts for damage and obstructions.
- check fuel lines and fuel filter for leakage and contamination.
- replace fuel filter if installed.

## 8.6 Visual Inspections and Installation Regulations

### 8.6.1 Heating Air System

#### CAUTION

The integration of the air heater into the vehicle's own air system requires an accurate adaptation and is not recommended.

The heater may be used for heating the passenger and driver cabin in the fresh air mode of operation and for load top compartments in the fresh air or circulation air mode of operation. If an air heater is installed in a loading compartment for circulation air mode of operation the inside of the entrance door shall be labeled as follows: "With heater on no personnel allowed in loading area with door closed!"

Due to the danger of poisoning or suffocation the air heating system air intake must be arranged in a way that under normal operating conditions exhaust fumes from the vehicle engine are unlikely to be sucked in, not even when a downstream fan is in use, e.g. by drawing air from the engine compartment.

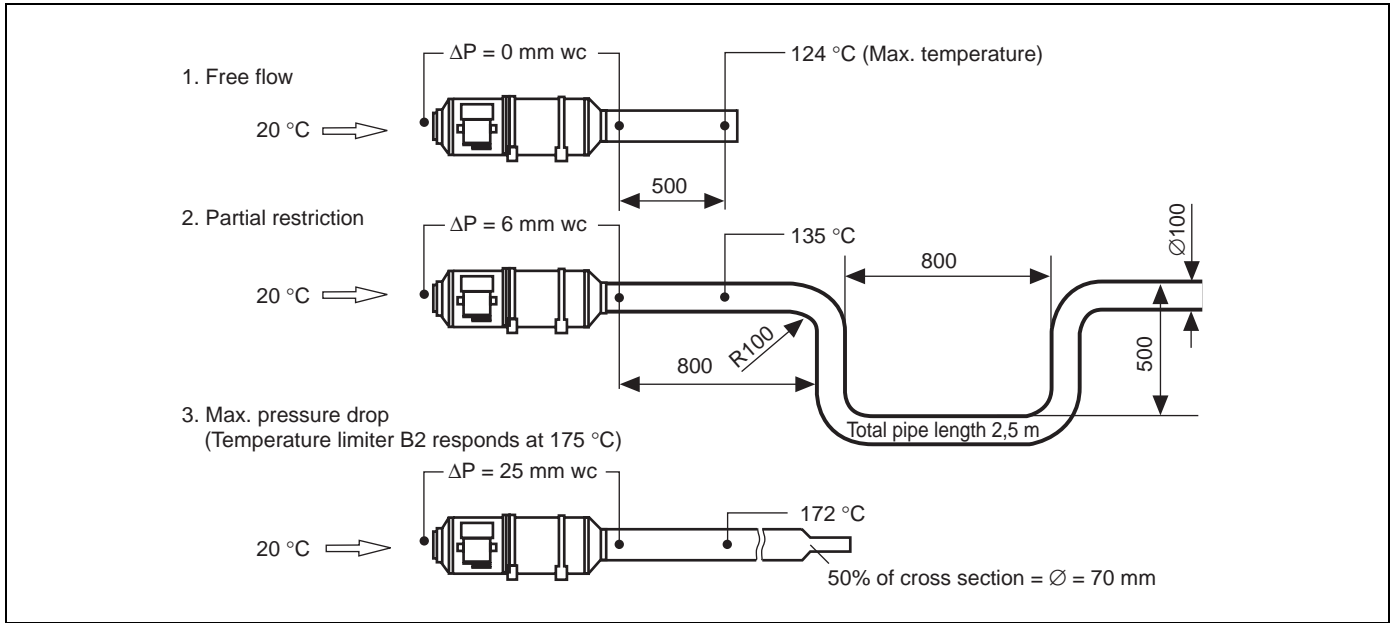

Fig. 801 Hot Air Temperatures with Drop of Pressure (12V Heaters)

The heating air intake temperature must not exceed +30° C.

Heating air duct minimum inner diameter: 100 mm

Past a brandnig (Y union) a heating air duct inner diameter of 80 mm is permitted.

Maximum air pressure difference between suction and pressure side of heating air duct:

2.5 mbar (25 mm wc)	12V/24V to 09.97
4.0 mbar (40 mm wc)	24V from 10.97 or retrofit

When exceeding this value the temperature limiter is very likely to respond. The heating air hose must be secured at its joints.

The air heater, when used in the ventilation mode of operation, may also be used without any further accessories when observing the air intake temperature limitation (a heating air flow short circuit should be avoided).

8.6.2 Fuel Supply

Fuel is tapped from the fuel reservoir of the vehicle or from a separate fuel tank. Permitted pressures at the fuel tapping location are listed in Fig. 802.

Permitted fuel feed suction height S (m)	At max. permissible negative pressure (bar) in fuel tank
0.00	-0.10
0.50	-0.06
1.00	-0.02

8.6.2.1 Fuel Tapping

Vehicles with big engines (trucks) fuel tapping must be from the fuel reservoir or a separate unpressurised fuel tank (Fig. 803, 804 and 805). This separate fuel tapping avoids an influence on the pressure.

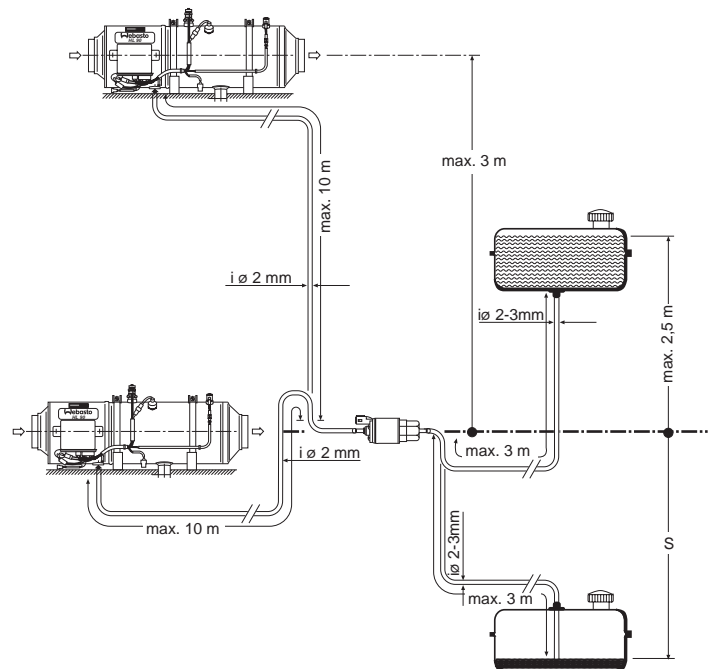

Fig. 802 Fuel Supply

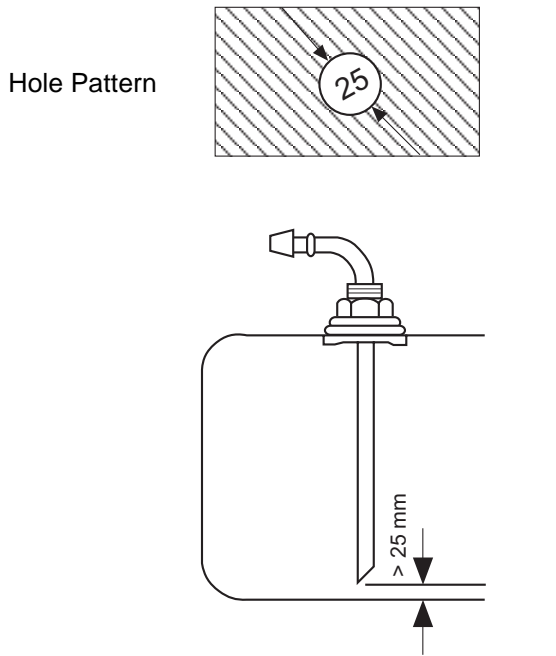

Fig. 803 Webasto Fuel Tank Tap \*

\* Use fuel tank tap only on metal fuel tanks

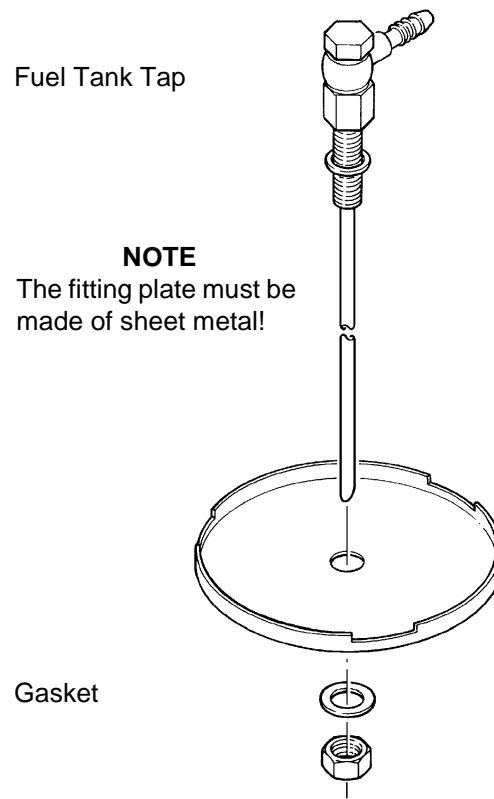

Fig. 805 Fuel Tapping from Plastic Tank (tapping via fitting plate)

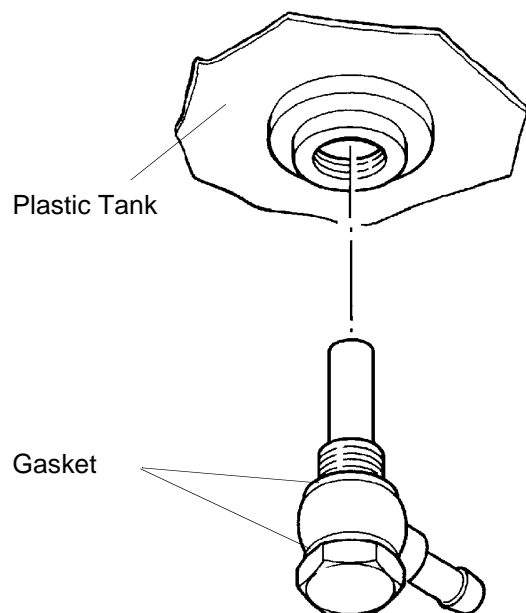

Fig. 804 Fuel Tapping from Plastic Tank (tapping via fuel drain plug)

**NOTE**

The fitting plate must be made of sheet metal!

**8.6.2.2 Fuel Lines**

Fuel lines may only be steel, copper, or plastic lines made of unhardened, light and temperature stabilised PA 11 or PA 12 (e.g. Mecanyl RWTL) according to DIN 73378. As in most cases a permanently rising fuel line routing cannot be ensured, the inner diameter must not exceed a certain value. Starting from an inside diameter of 4 mm, air or gas bubbles accumulate resulting in malfunctions should the lines be descending or having sags. The diameters specified in Fig. 801 ensure no disturbing formation of bubbles.

A descending line routing from the dosing pump to the heater should be avoided.

Loose fuel lines must be secured in order to avoid sagging. The installation must ensure protection against stone impacts and **undue temperatures** (exhaust line). The fuel line joints are to be secured against slipping with hose clamps.

**Connection of 2 Pipes with Hose**

The proper connection of fuel lines with hoses is shown in Fig. 806.

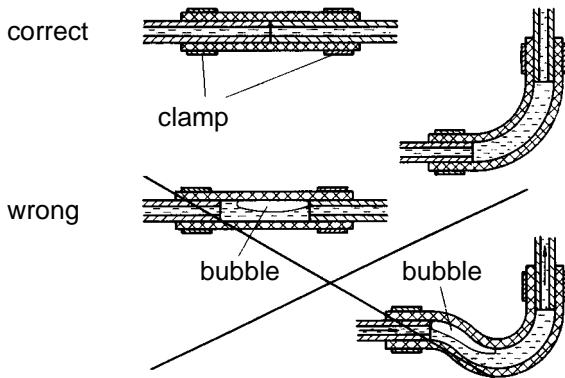

Fig. 806 Pipe / Hose Connection

**8.6.3 Dosing Pump**

The dosing pump is a combined delivery, dosing and shut-off system and is subject to certain installation criteria (Fig. 802 and 807).

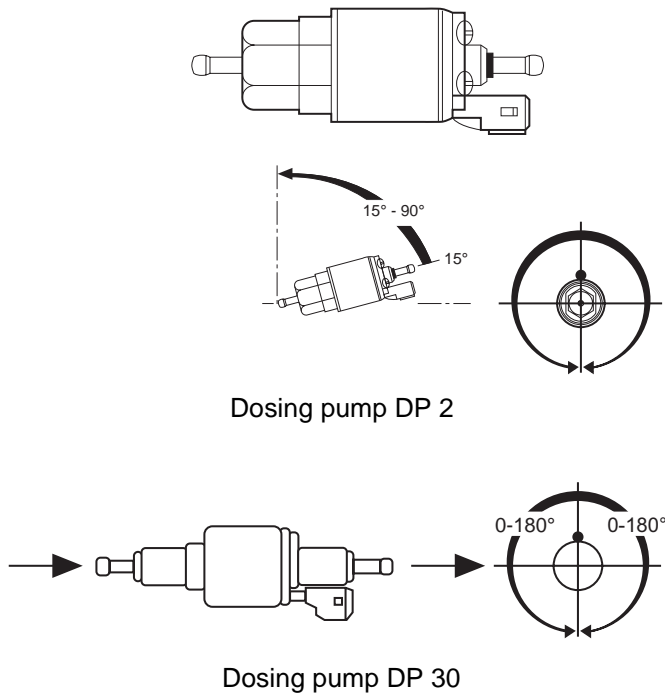

Fig. 807 Dosing Pump, Installation and Attachment

**8.6.3.1 Installation Location**

Prior to installation of dosing pump ensure that the pressure at the tapping location does not exceed 0.2 bar.

It is advantageous to mount the dosing pump in a cool location. The ambient temperature must never exceed +40° C during operation.

Dosing pump and fuel lines must not be installed in locations exposed to heat radiated by hot vehicle components. A heat shield is to be provided as necessary. The preferred installation location is near the tank.

**8.6.3.2 Installation and Attachment**

The dosing pump is to be attached with anti-vibration mounts. The installation location is limited according to Fig. 807 to ensure sufficient self venting capability. Due to the danger of corrosion the plug connection between dosing pump and dosing pump cable loom may only use Webasto original parts.

**8.6.4 Fuel Filter**

If there is the probability of contaminated fuel only the Webasto filter, Order No. 487 171, may be used. Installation possibly vertical up to horizontal the most (observe direction of flow).

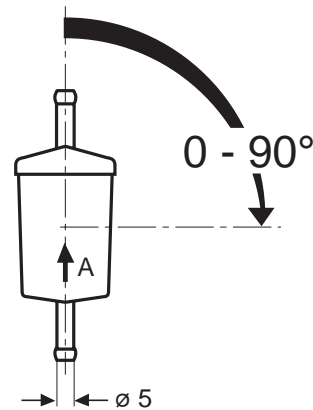

Fig. 808 Fuel Filter

**8.6.5 Combustion Air Supply**

Combustion air must under no circumstances be extracted from rooms with persons. The combustion air inlet must not point towards the forward direction of motion. It must be located so that no clogging by contamination is to be expected.

If the air heater is located in a closed installation box, combustion air must be taken in from and the exhaust routed to the exterior. The splash water proof feedthroughs must not allow exhaust fumes to enter the vehicle interior.

In order to silence the air intake noises an air intake muffler (included in delivery of 24 v units) is recommended (Fig. 809). The muffler is fitted onto the air intake pipe.

**NOTE**

For 12 V units it is recommended to install an air intake muffler (Order No. 876 59A).

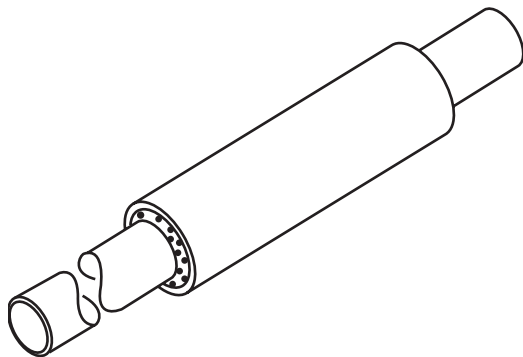

Fig. 809 Air Intake Muffler

**8.6.6 Exhaust Line**

Rigid pipes made of unalloyed or alloyed steel with a minimum wall thickness of 1.0 mm have to be used as exhaust line or flexible pipes made of alloyed steel only. The exhaust pipe is secured to the air heater e.g. with a clamp.

The exhaust muffler is preferably mounted near the air heater. The direction of flow is optional.

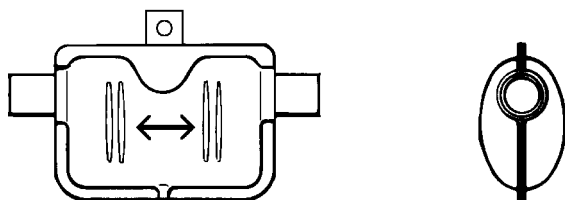

Fig. 810 Exhaust Muffler, Direction of Flow

Operation of the air heater is also permitted without muffler.

**8.6.7 Combustion Air Intake and Exhaust Lines**

Length of combustion air intake line:  
 with muffler: max. 3.0 m  
 without muffler: max. 5.0 m

Length of exhaust line: max. 5.0 m

Both lines are to be routed away from the heater in a decline. If this is not possible, a condensate drain hole Ø 4 mm must be provided at the lowest point.

Inner diameter of lines:  
 combustion air line: 30 mm  
 exhaust line: 38 mm

Smallest bending radius:  
 combustion air line: 45 mm  
 exhaust line: 85 mm

In order to ensure an angle of  $90^\circ \pm 10^\circ$ , an attachment is required not further than 150 mm away measured from the exhaust pipe end.

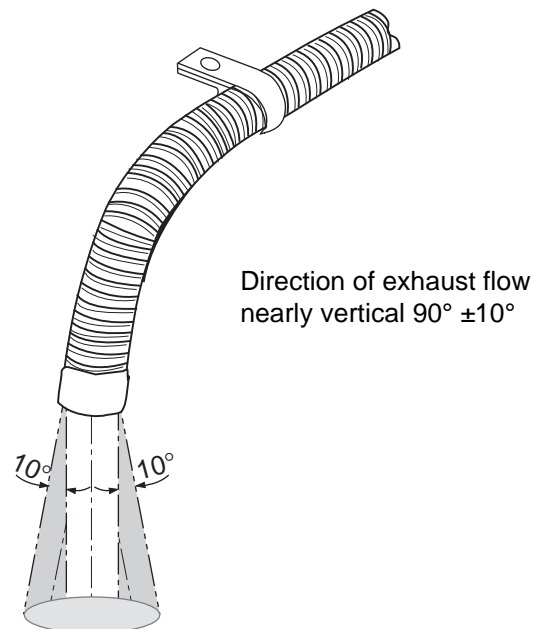

Fig. 811 Exhaust Pipe Outlet, Installation Position

**WARNING**

Other installation position of exhaust pipe outlet than shown in Fig. 811 may cause fires.

Sum of bends:  
 combustion air line: max. 360°  
 exhaust line: max. 360°

**8.7 Removal and Installation****CAUTION**

In installed condition only the following disassembly or removal procedures are permitted should enough space for removal allow such action:

- replacement of control unit
- replacement of glow plug
- replacement of flame sensor and its receptacle
- replacement of temperature limiter

**8.7.1 Heater, Removal and Installation****8.7.1.1 Removal**

1. Disconnect vehicle battery.
2. Disconnect electrical connector of wiring harness from control unit.
3. Disconnect cable to dosing pump at its disconnect.
4. Disconnect fuel supply inlet on heater. Close fuel line with plug.
5. Disconnect combustion air inlet and exhaust outlet on heater.
6. Open tightening straps.
7. Remove heater from supports.

**8.7.1.2 Installation**

1. Retighten screws of supports with 12 Nm.
2. Locate heater for installation and secure with tightening straps (locate straps between wiring harness and outer case).
3. Connect fuel supply line to heater fuel inlet and secure with clamp tightening to 2 Nm.
4. Secure combustion air inlet and exhaust outlet on heater.
5. Route cable to dosing pump and reconnect at its disconnect point.
6. Connect wiring harness connector to control unit.
7. Tighten screws of turnbuckles with 5 Nm.
8. Reconnect vehicle battery.
9. Bleed fuel supply system.

**8.7.2 Control Unit, Replacement****NOTE**

The replacement procedure for the control unit is identical with the heater installed or removed.

Perform replacement in accordance with 9.2.1.

**8.7.3 Glow Plug, Replacement****NOTE**

The replacement procedure for the glow plug is identical with the heater installed or removed.

Perform replacement in accordance with 9.2.2.

**8.7.4 Flame Sensor, Replacement****NOTE**

The replacement procedure for the flame sensor is identical with the heater installed or removed.

Perform replacement in accordance with 9.2.3.

**8.7.5 Temperature Limiter, Replacement****NOTE**

The replacement procedure for the temperature limiter is identical with the heater installed or removed.

Perform replacement in accordance with 9.2.4.

**8.8 First Operation**

After heater installation the fuel supply system must be thoroughly bled.

**NOTE**

Long fuel lines may require several switch-ons for priming the fuel line to the heater.

During a test run of the air heater all connections are to be checked for no leakage and tight fit. Should the heater during operation enter an error lockout condition, perform troubleshooting.

## **9 Repair**

### **9.1 General**

This section describes the repairs that may be performed on the air heater HL 90 when removed. Any further disassembly will void the warranty. For re-assembly only components of the original spare part kits are to be used.

#### **9.1.1 Work on Components after Disassembly**

All gaskets located between disassembled components must always be replaced and discarded.

##### **9.1.1.1 Cleaning**

- All components disassembled must be cleaned with cleaning spirit and subsequently blown dry with air.

##### **9.1.1.2 Visual Inspection**

- Examine all components for damages (cracks, deformation, wear, etc.) and replace as necessary.
- Examine connectors and wiring for corrosion, loose contacts, wrong crimping, etc. and repair as necessary.
- Check terminals for corrosion and contacts for security. Repair as required.

9.2 Disassembly and Assembly

9.2.1 Control Unit, Replacement

9.2.1.1 Removal

1. Disconnect electrical connector on control unit.
2. Remove screws (14, Fig. 901) and control unit (13).

3. Perform procedures on components after disassembly (refer to 9.1.1).

9.2.1.2 Installation

1. Locate control unit (13, Fig. 901) in installation position and secure with screws (14).
2. Torque screws with  $2.5 \pm 0.2$  Nm.
3. Connect electrical connector to control unit.

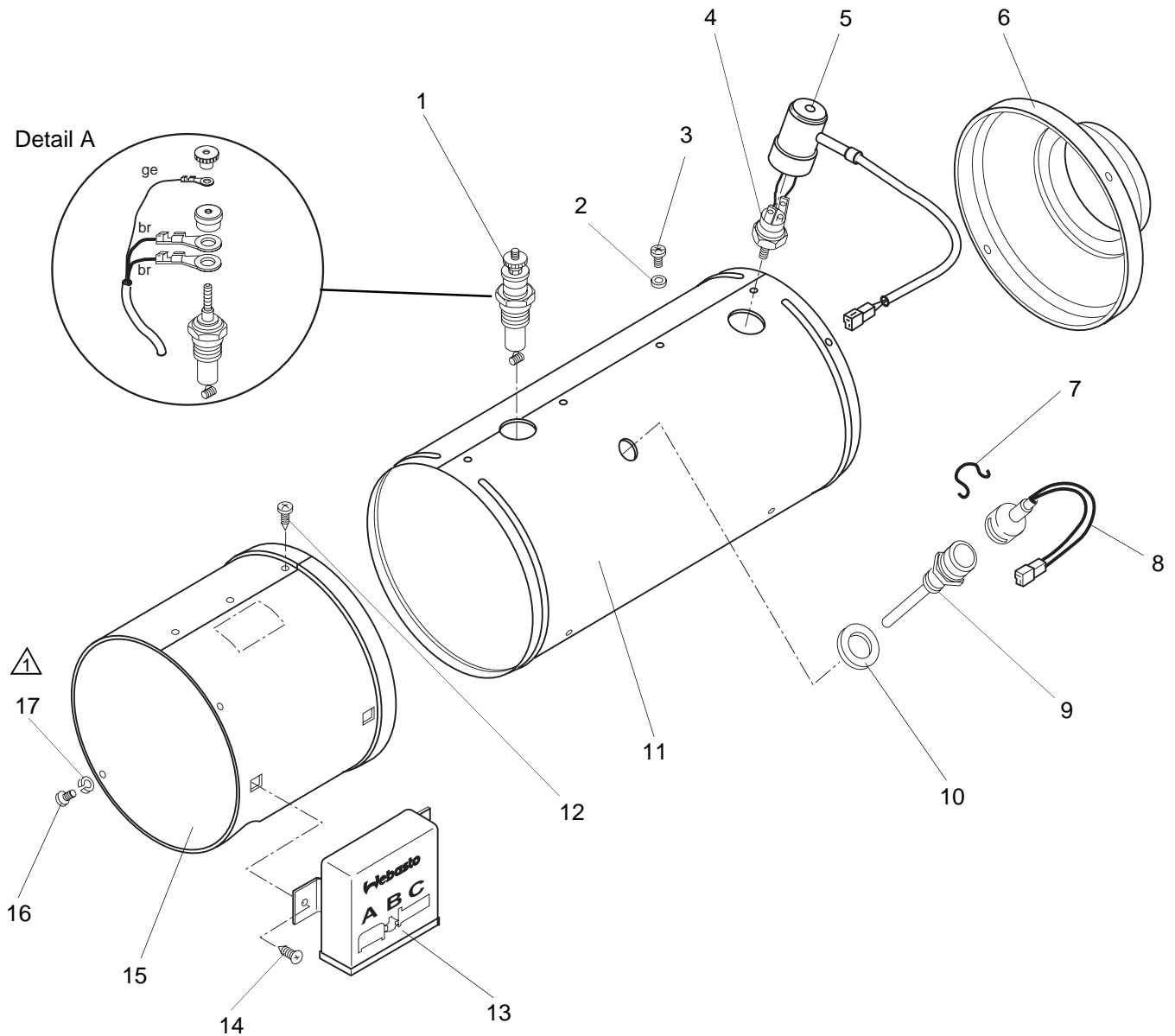

⚠ Spring washers (17) not applicable for orifice plate made of plastic.

- |                           |                      |
|---------------------------|----------------------|
| 1 Glow plug               | 10 Grommet           |
| 2 Lock washer             | 11 Outer case        |
| 3 Screw                   | 12 Screw (3)         |
| 4 Temperature limiter     | 13 Control unit      |
| 5 Silicone cap            | 14 Screw (2)         |
| 6 End cap                 | 15 Half case         |
| 7 Retaining clip          | 16 Screw (3)         |
| 8 Flame sensor            | 17 Spring washer (3) |
| 9 Flame sensor receptacle |                      |

Fig. 901 Replacement of Control Unit, Glow Plug, Flame Sensor and Temperature Limiter

## 9.2.2 Glow Plug, Replacement

### 9.2.2.1 Removal

1. Remove knurled nut from glow plug.
2. Withdraw cable and isolator.
3. Unscrew glow plug (1, Fig. 901) and remove.
4. Perform procedures on components after disassembly (refer to 9.1.1).

### 9.2.2.2 Installation

1. Apply high temperature grease (Copaslip) to thread of glow plug.
2. Manually screw glow plug (1, Fig. 901) in and tighten with  $20 \pm 2.0$  Nm.
3. Bring cable and isolator in assembly position as shown in Fig. 901, Detail A and secure with knurled nut.
4. Tighten knurled nut with  $2.0 \pm 0.5$  Nm.

## 9.2.3 Flame Sensor, Replacement

### 9.2.3.1 Removal

1. Disconnect electrical connection to flame sensor.
2. Remove spring (7, Fig. 901) from flame sensor (8) and withdraw flame sensor.
3. Unscrew flame sensor receptacle (9) and remove.
4. Remove grommet (10) and discard.
5. In counterlight visually check quartz glass rod of flame sensor receptacle for transparency.
6. Perform procedures on components after disassembly (refer to 9.1.1).

### 9.2.3.2 Installation

1. Locate new grommet (10, Fig. 901) flush in installation position.
2. Apply high temperature grease (Copaslip) to thread of flame sensor receptacle.
3. Manually screw flame sensor receptacle in place and torque with  $20 \pm 2.0$  Nm.
4. Plug on flame sensor (8) and secure with retaining clip (7).
5. Make electrical connection of flame sensor to wiring harness.

## 9.2.4 Temperature Limiter, Replacement

### 9.2.4.1 Removal

1. Disconnect electrical connection to temperature limiter.
2. Slide silicone cap (5, Fig. 901) up enough to make hexagon of temperature limiter (4) accessible.
3. Unscrew temperature limiter and remove.
4. Perform procedures on components after disassembly (refer to 9.1.1).

### 9.2.4.2 Installation

1. Screw temperature sensor (4, Fig. 901) in by hand and tighten with  $0.8 \pm 0.2$  Nm.
2. Form-fit silicone cap (5).
3. Make electrical connection of temperature limiter to wiring harness.

## 9.2.5 Drive, Replacement

### 9.2.5.1 Removal

1. Remove control unit (see 9.2.1.1).
2. Disconnect electrical connector (9 and 25, Fig. 902) and carefully push into half case together with grommet (8).
3. Remove screws (12 and 16, Fig. 901) and spring washers (17). Slightly widen half case and slide off over air intake pipe.
4. Remove screws (19, Fig. 902) and lock washers (20).
5. Withdraw drive from heat exchanger and remove.
6. Perform procedures on components after disassembly (refer to 9.1.1) or continue to disassemble drive (see 9.2.6).

### 9.2.5.2 Installation

1. Apply vaseline to O-ring (22, Fig. 902).
2. Bring drive with heat exchanger in assembly position secure with screws (19, Fig. 902) and lock washers (20).
3. Tighten screws with  $5.5 \pm 0.5$  Nm.
4. Slightly widen half case (15, Fig. 901), route electrical connector (9 and 25, Fig. 902) with cable to exterior and push grommet (8) into opening for proper fit in place.
5. Position half case (15, Fig. 901) for assembly and secure with screws (12).
6. Secure half case (15) with screws (16) and spring washers (17).
7. Tighten screws (12 and 16) with  $2.5 \pm 0.2$  Nm.
8. Secure cap (1, Fig. 902) with screws (14) and tooth washers (13).
9. Tighten screws (14) with  $2.5 \pm 0.2$  Nm.
10. Install control unit (see 9.2.1.2).

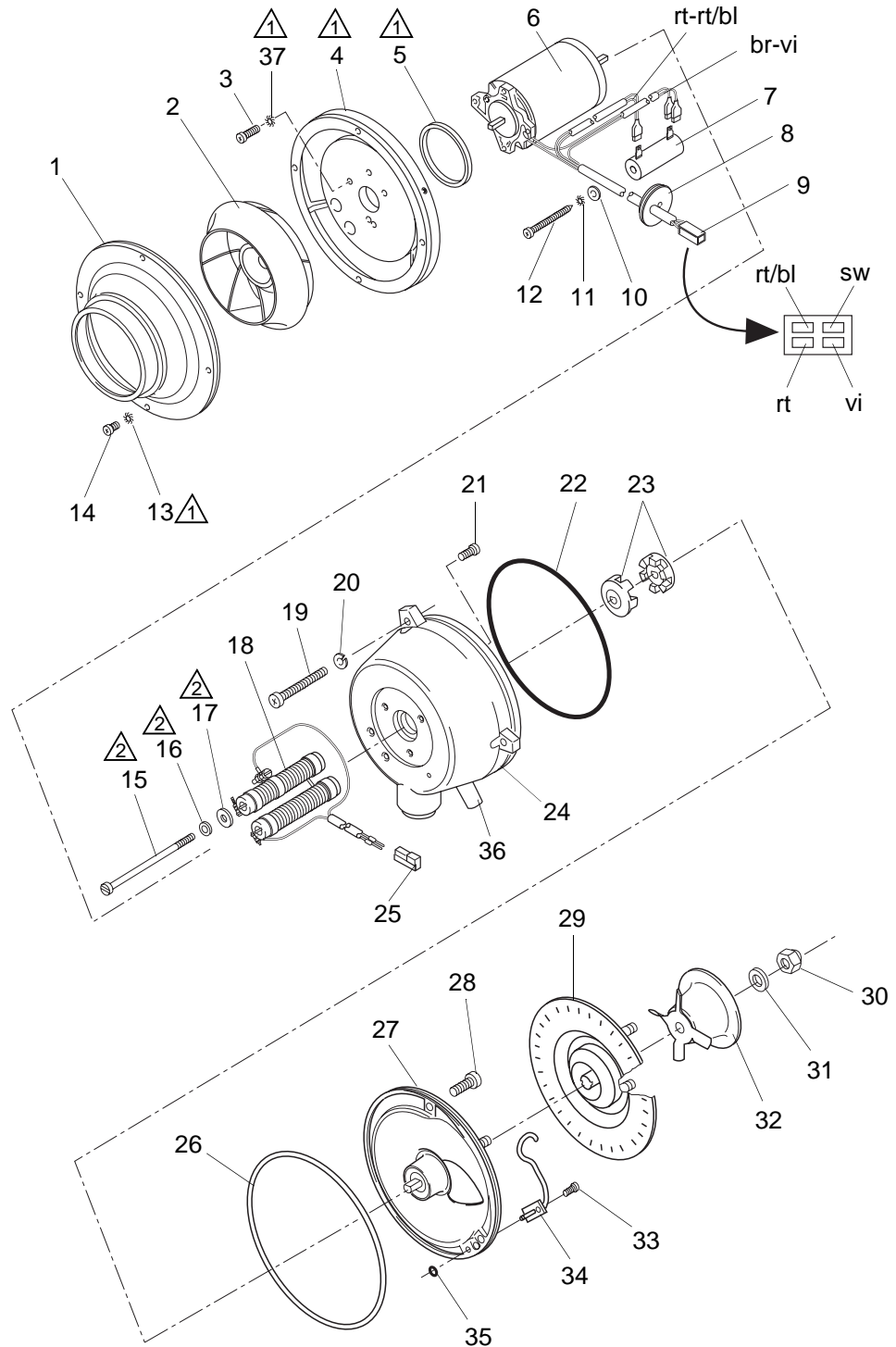

**NOTE**

⚠ Orifice plate (4) made of plastic has no tooth washers (13) and spacer ring (5). Screws (3) are then locked with tooth washers (37).

⚠ If screws (15) are sheet metal type screws, there are no locking rings (16) and washers (17).

- |                        |                           |   |
|------------------------|---------------------------|---|
| 1 Cap                  | 14 Screw (4)              | 27 Bypass fan   |
| 2 Rotor                | 15 Screw (2)              | 28 Screw (3)  |
| 3 Screw (3)            | 16 Locking ring (2)       | 29 Atomiser assembly                                    |
| 4 Orifice plate        | 17 Washer (2)             | 30 Cap nut  |
| 5 Spacer ring          | 18 Glow plug resistor (2) | 31 Washer   |
| 6 Motor                | 19 Screw (3)              | 32 Displacer  |
| 7 Resistor             | 20 Lock washer (3)        | 33 Screw (2)  |
| 8 Grommet              | 21 Screw (3)              | 34 Fuel line  |
| 9 Electrical connector | 22 O-ring                 | 35 O-ring   |
| 10 Washer              | 23 Clutch                 | 36 Fuel inlet with double conical ring and coupling nut |
| 11 Tooth washer        | 24 Air intake housing     | 37 Tooth washer (3)                                     |
| 12 Screw               | 25 Electrical connector   |   |
| 13 Tooth washer (4)    | 26 Round cord ring        |   |

Fig. 902 Disassembly of Drive

### 9.2.6 Drive, Disassembly and Assembly

The disassembly of the drive is broken down into two subjects:

- heating air supply/ electrical components
- combustion air supply / fuel ducting / motor

#### 9.2.6.1 Heating Air Supply / Electrical Components, Disassembly

The following steps should be performed with the heater fully assembled.

1. For removal of cap (1, Fig. 902) remove screw (14) and tooth washers (13) as required.
2. Using two levers (wide blade screw drivers, etc.) lever plastic rotor (2) off from motor shaft by pushing against orifice plate (4). Remove orifice plate and spacer ring (5) by removing screws (3).

#### NOTE

When disassembling and disconnecting wiring and connectors make sure to observe wiring arrangement, see Fig. 902.

3. Loosen screws (15) and remove glow plug resistor (18), locking ring (16) and washer (17).
4. Remove screw (12), tooth washer (11) and washer (10).
5. Disconnect blade terminal from electrical connectors (9 and 25). Check condition of grommet (8) and replace as necessary.
6. Disconnect electrical connectors from resistor (7) and remove resistor.

#### 9.2.6.2 Combustion Air Supply / Fuel Ducting / Motor, Disassembly

1. Remove cap nut (30), washer (31) and displacer (32).
2. Withdraw atomiser assembly (29).
3. Remove screws (33) and fuel line (34).
4. Remove screws (28).
5. Carefully pull bypass fan (27) out of air intake housing (24).

#### CAUTION

Remove bypass fan by a slight axial pull on shaft. Remove major contamination on edge zone to air intake housing and slightly grease as required.

6. Withdraw one half of clutch (23); remove round cord ring (26) and discard.
7. Remove O-ring (35) from air intake housing and discard.
8. Pull other half of clutch (23) from motor shaft.
9. Remove screws (21) and separate air intake housing (24) from motor (6).

10. Remove O-ring (22) and discard.
11. Perform procedures on components after disassembly (refer to 9.1.1).

#### CAUTION

Clean bypass fan with pressurized air only.

#### 9.2.6.3 Assembly

1. Position new O-ring (22, Fig. 902) on air intake housing for assembly.
2. Assemble air intake housing (24) and motor (6) with screws (21).
3. Slide half of clutch (23) onto motor shaft in air intake housing (24).
4. Position new O-ring (35) at fuel transfer point in air intake housing.
5. Position new round cord ring (26) in bypass fan (27).
6. Slide other half of clutch (23) onto shaft in bypass fan (27).

#### NOTE

Fuel line must be aligned with fuel transfer point (O-ring); clutch (23) must also engage.

7. Assemble bypass fan (27) and air intake housing (24) with screws (28). Torque screws to 4 Nm.
8. Secure fuel line (34) in bypass fan (27) with screws (33) torqued to 1.5 Nm.
9. Slide atomiser assembly (29) onto shaft until arrested by drive pin.
10. Slide displacer (32) onto shaft and secure with washer (31) and cap nut (30). Torque cap nut to 2.5 Nm.
11. Mount resistor (7) with screw (12), tooth washer (11) and washer (10). Torque screw to 2 Nm.
12. Connect electrical connectors to resistor (7) (refer to Section 7 as required).

#### NOTE

Torque for cap screws and sheet metal screws is  $5.5 \pm 0.5$  Nm.

13. Secure glow plug resistors (18) with screws (15). No locking rings (16) and washers (17) when sheet metal screws are in use.
14. Slide on grommet (8) at wiring connect points of electrical connectors (9 and 25); reconnect cable wires to relevant connectors to restore proper electrical functions (refer to Section 7 as required).
15. Locate spacer ring (5) and orifice plate (4) for assembly so that spacer ring is centered on fan of motor (6). There is no spacer ring (5) if plastic orifice plate is in use.
16. Secure orifice plate (4) and spacer ring (5) with screws (3) and torque to  $5.5 \pm 0.5$  Nm. Locate tooth washers (37) between orifice plate (plastic) and screw (3).
17. Press rotor (2) onto shaft until seated against stop.

**CAUTION**

Align interlock surfaces in rotor and on motor shaft.

**WARNING**

The 12 V type heater has only one glow plug resistor (18) fitted. Make sure to close second opening in air intake housing with a screw plug.

**NOTE**

Check fuel line position with gauge No. 866 45A by positioning gauge on drive shaft of bypass fan and reading the value  $0.5 \pm 0.5$ . Bend as required to adjust distance (see Figure).

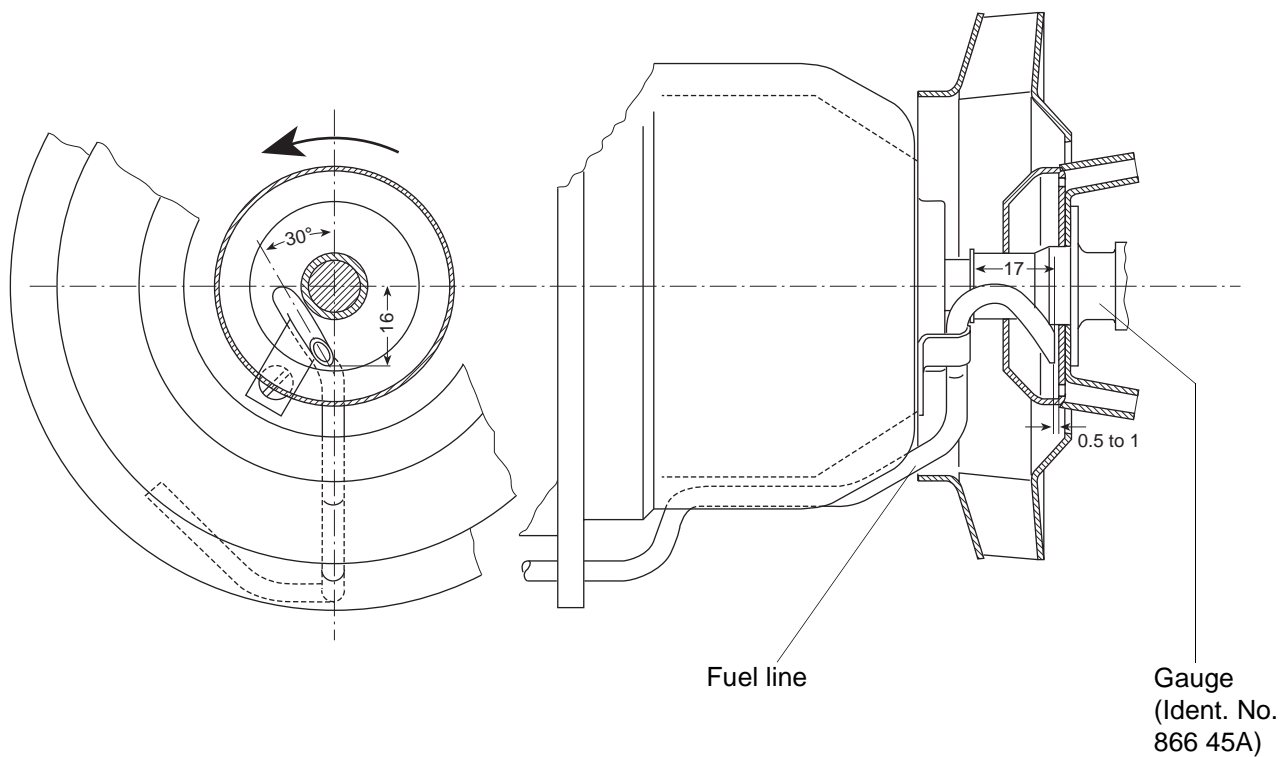

## 9.2.7 Heat Exchanger, Replacement

### 9.2.7.1 Removal

1. Remove control unit (refer to 9.2.1.1).
2. Remove glow plug (refer to 9.2.2.1).
3. Remove flame sensor (refer to 9.2.3.1).
4. Remove temperature limiter (refer to 9.2.4.1).
5. Remove drive (refer to 9.2.5.1).
6. Remove screws (3, Fig. 901) and lock washers (2) from outer case (11) and remove from end cap (6).
7. Pull off end cap (6).
8. Carefully widen outer case and remove heat exchanger.
9. Remove nuts (1, Fig. 903) and lock washers (2).
10. Pull rear wall (3) out of heat exchanger and remove sealing cord (4).
11. Discard sealing cord.
12. Perform procedures on components after disassembly (refer to 9.1.1).

### 9.2.7.2 Installation

1. Apply sealing and bonding compound (Ident. No. 666 05A) to mating surfaces of sealing cord (4, Fig. 903) and heat exchanger (5) and locate with rear wall (3) in heat exchanger (5) for assembly.
2. Secure rear wall (3) with nuts (1) and lock washers (2).
3. Torque nuts (1) to  $1.5 \pm 0.2$  Nm.

#### NOTE

When performing the following step ensure that all connections and screw holes in outer case are centered.

4. Locate heat exchanger with outer case (11, Fig. 901) and end cap (6) and assemble with screws (3) and lock washers (2).
5. Torque screws (3) to  $2.5 \pm 0.2$  Nm.
6. Install drive (refer to 9.2.5.2).
7. Install temperature limiter (refer to 9.2.4.2).
8. Install flame sensor (refer to 9.2.3.2).
9. Install glow plug (refer to 9.2.2.2).
10. Install control unit (refer to 9.2.1.2).

- 1 Nut (3)
- 2 Lock washer (3)
- 3 Rear wall
- 4 Sealing cord
- 5 Heat exchanger

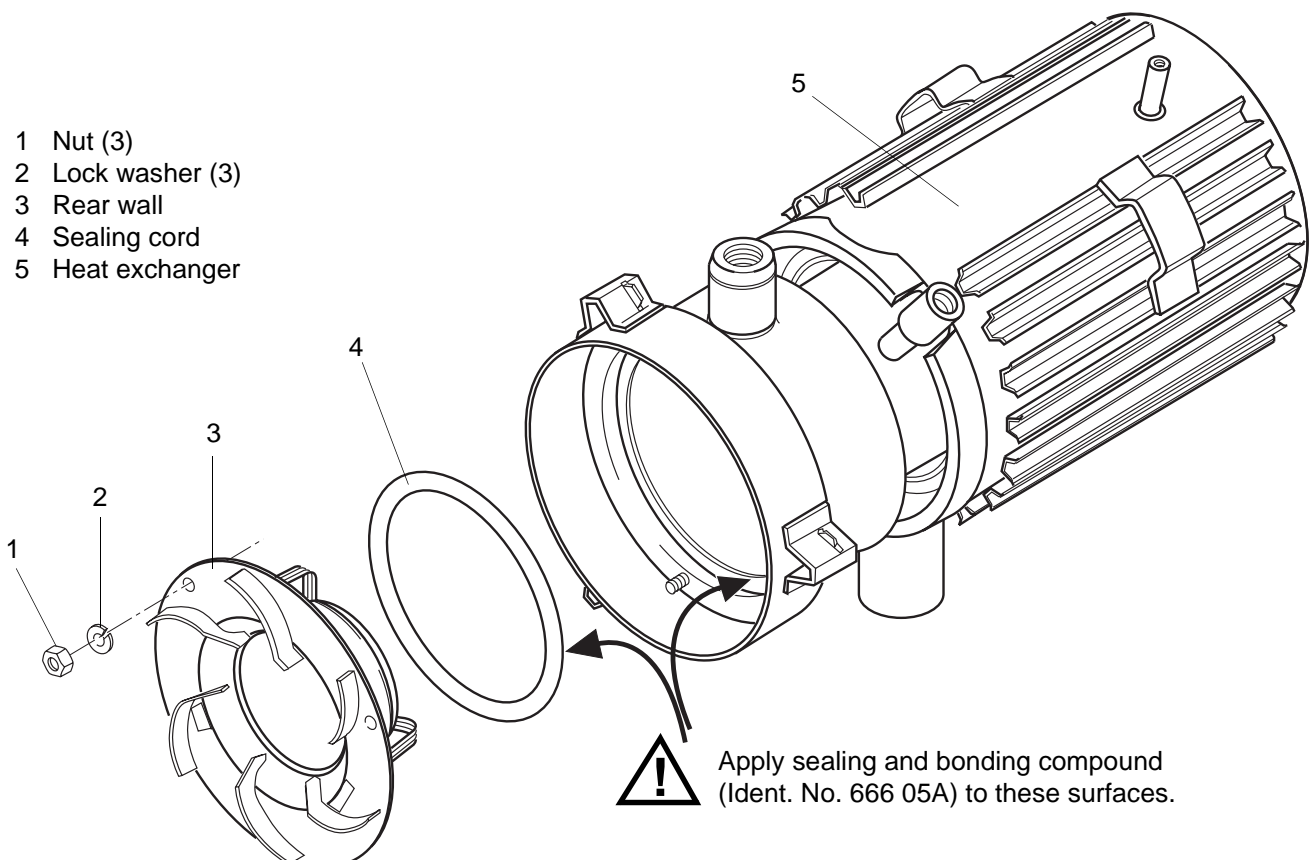

Fig. 903 Replacement of Heat Exchanger

## Your Notes

## **10 Storage and Shipping**

### **CAUTION**

When shipping a complete heater assembly it must be drained completely. No fuel is allowed to escape from a packaging or during shipping.

Dummy plugs must be fitted to the fuel lines.

In storage the ambient temperatures specified in Section 4 must not be exceeded.

## Your Notes