

BlueHeat *Coolant Heater (24 Volt Diesel)*

GM 3500 HD Military Vehicle

Model Year 2003 with 6.6 Liter Duramax Diesel

Installation Instructions

Fuel Standpipe & Fuel Metering Pump

Preparations

General Information

The installation instructions provided in this manual will take you step by step through the installation process. Follow all directions carefully and read all Warnings, Cautions and Attention notations as you work through these instructions and the installation of the fuel standpipe and fuel metering pump.

⚠ CAUTION

Do not deviate from the installation instructions provided in this manual. Failure to comply with the installation instructions provided may result in poor operation or damage to heater and vehicle components.

Tools Required

Special Tools:

- 3/8" Drive Eliminator Micrometer Torque Wrench - Product Number 64-140 (Armstrong Industrial Tools)
- 3/8" Drive Eliminator Thru-Hole Extension - Product Number 11-932 (Armstrong Industrial Tools)
- 9/16" 6 Point 3/8" Drive Eliminator Socket - Product Number 11-618 (Armstrong Industrial Tools)
- Cable tie gun / cutter (Paladin Tools 1828.1)
- TDM Designed Standpipe Shaping/Cutting Jig
- TDM Designed Fuel Sender Boring Jig - see image below



Hand Tools:

- Standard Torque Wrench - Scaled for Newton meters, or pounds/foot or pounds/inch.
- 10 mm Socket and Drive Ratchet
- 10 mm Combination Wrench
- 13 mm Combination Wrench
- #2 Phillips Head Screwdriver
- Hand Drill with 9.5 mm (3/8 in.) Drill Bit
- Side-cut Pliers
- Tube cutter
- Hose cutter
- Razor Knife or equivalent

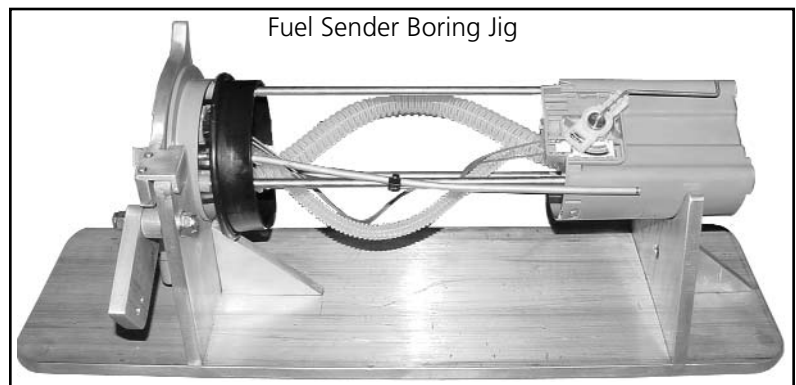

Miscellaneous:

- Silicone Spray Lubricant or equivalent
- Vehicle Manufacturer's Service Reference Manual

Torque Specifications Table

ITEM	Nm	lb-ft	lb-in
Standpipe Nut	9.0 - 9.5	6.6 - 7	80 - 84
Fuel Line Clamps	1.0 - 1.4	0.7 - 1	8.8 - 12.4
Fuel Pump Retaining Clamp Cap Screw and Nut	10 - 10.5	7.4 - 7.75	88.5 - 93

Kit Contents

Fuel Standpipe (Figure 1)

- 1 Fuel Standpipe with 2 sealing washers and lock nut.

Fuel Pump Installation Parts (in bag, Figure 1)

- 1 Fuel Pump - 24 Volt DP 30.2
- 1 P-Clip - Fuel Pump Retaining
- 1 Cap Screw - M6x20
- 1 Flanged Nut - M6
- 1 Fender Washer - M6
- 1 Mecanyl Fuel Line (2.0 meters)
- 3 Fuel Line Coupler
- 4 Fuel Line Clamp - 9.5-10.5 mm
- 7 Nylon Cable Tie



Fig. 1

Installation

- Unfasten and raise cargo box (if present) off of frame to gain access to fuel sender. Refer to vehicle manufacturer's service instructions.

Item 1 and 2:

- Disconnect fuel lines. Refer to vehicle manufacturer's service instructions.

Item 3:

- Disconnect wiring harness. Refer to vehicle manufacturer's service instructions.
- Remove fuel sender unit from fuel tank. Refer to vehicle manufacturer's service instructions.

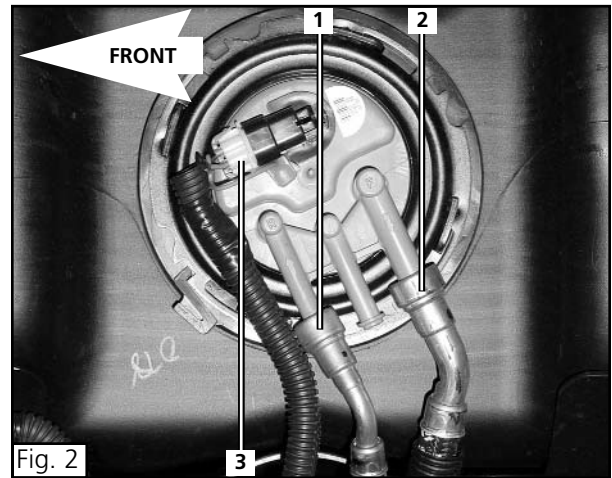

Fig. 2

Item 1:

- Drain excessive fuel from sender unit.
- Remove label from drilling area of sender. Place label elsewhere on sender.
- Place sender unit in jig as shown.

Item 2:

- Swing bore locating arm into position as shown.

Item 3:

- Bore 1/8 in. pilot hole into sender unit through pilot hole guide.
- Swing bore locating arm out of the way.

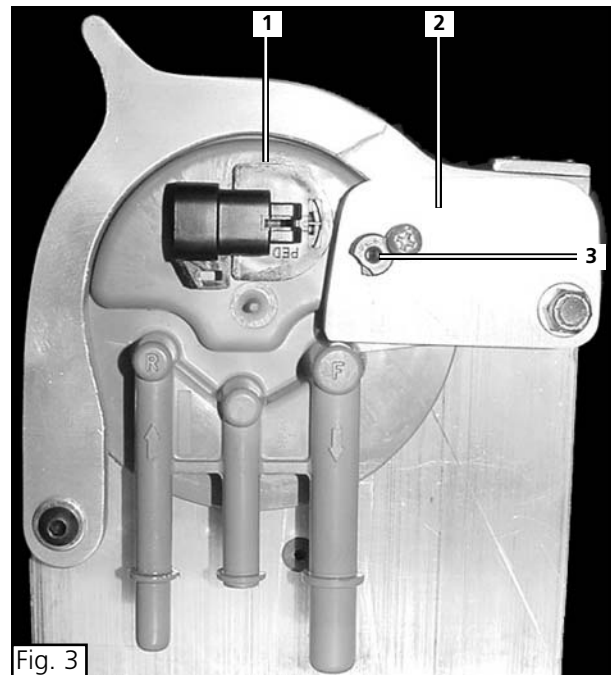

Fig. 3

Item 1:

- Enlarge pilot hole to size with a 9.5 mm (3/8 in.) drill bit or step bit.
- Remove any burrs after boring hole.

CAUTION!

Remove any burrs left around hole after boring! To ensure proper sealing, burrs MUST be removed from both sides of hole before fuel standpipe is installed.

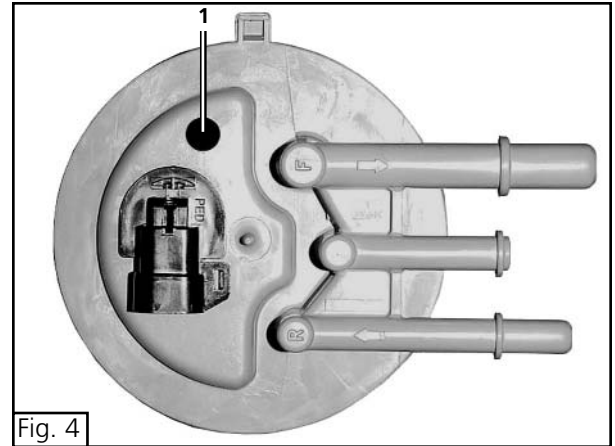

Fig. 4

Figure 5:

- Bend standpipe to shape using bending gauge/jig.
- Cut standpipe to length where indicated on the bending gauge/jig.



Fig. 5

Legend for Figure 6

- 1 Standpipe
- 2 Outer sealing washer
- 3 Sender unit
- 4 Inner sealing washer
- 5 Locking nut

- Assemble standpipe, sealing washers and locking nut with sender unit as shown in Figure 6.

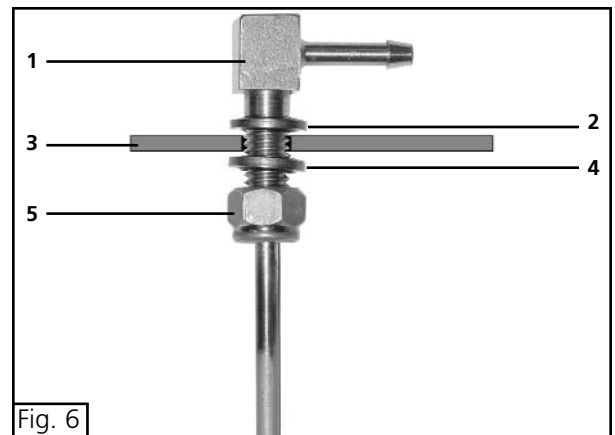

Fig. 6

Item 1 and 2:

- Position fuel standpipe outlet (1) as shown using the scribe line (2) on jig as a guide before tightening.

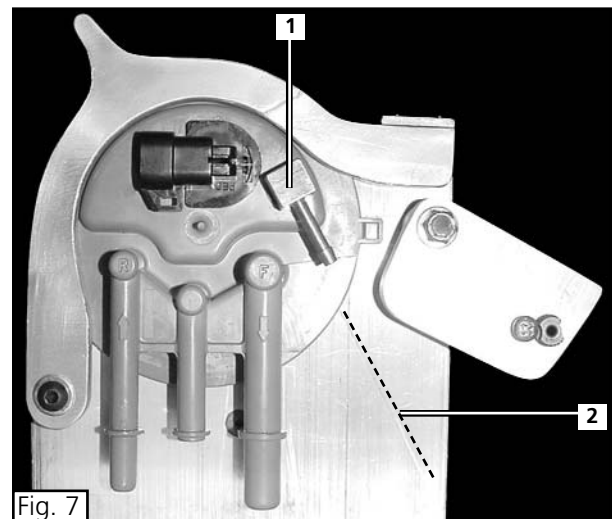

Fig. 7

Item 5:

- Torque tighten locking nut from underside of sender unit to 9.0 - 9.5 Nm using the special tools listed on page 1.

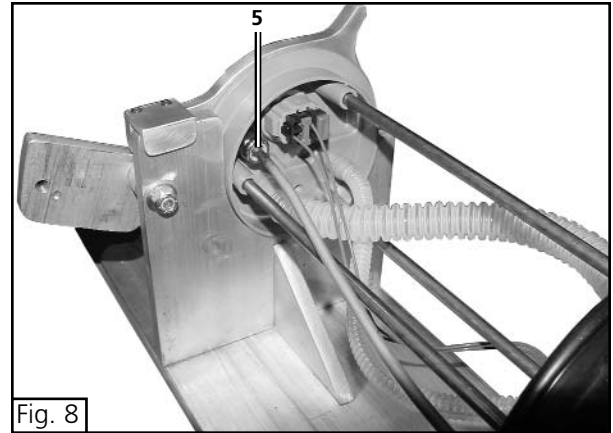

Fig. 8

Item 1 and 2:

- Secure standpipe tube (1) to sender unit with nylon cable tie (2) as shown.

Item 3:

- Ensure standpipe tube end does not rub on sender unit reservoir. Adjust bend if necessary.

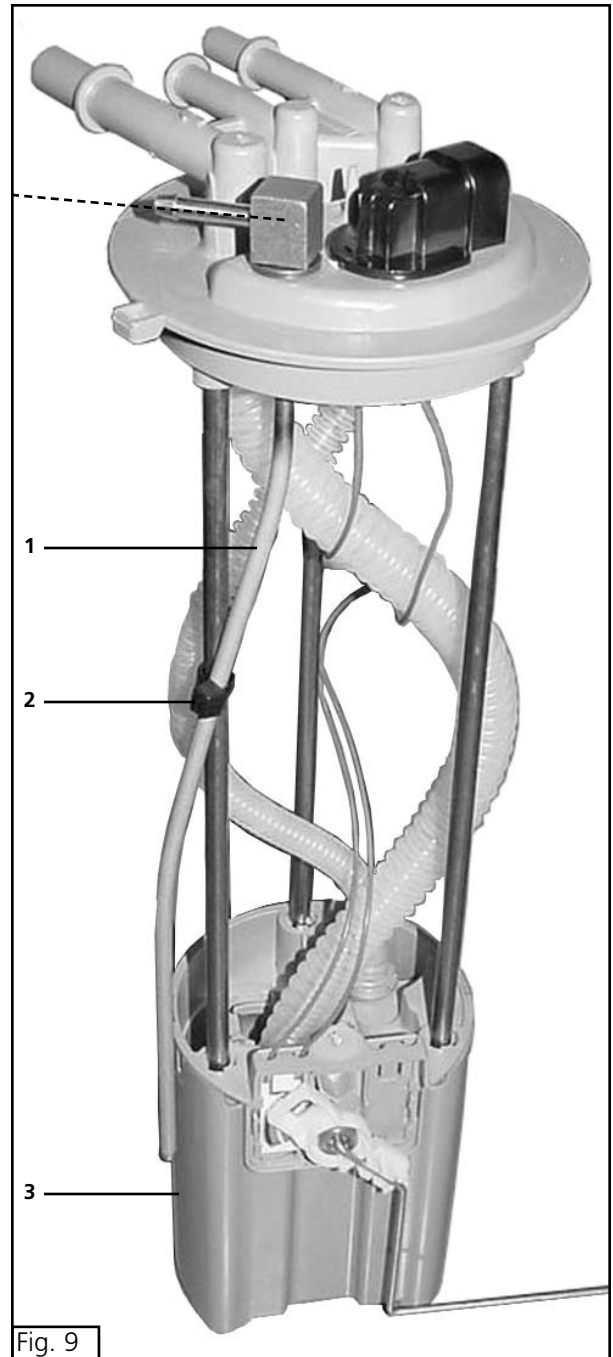

Fig. 9

Item 4:

- Push fuel line coupler onto end of fuel standpipe tube leaving 38 mm (1.5 in.) below end of tube.

Item 3:

- Secure coupler with a nylon cable tie using a cable tie gun.

ATTENTION!

A cable tie gun is recommended for applying nylon cable ties ensuring proper tensioning of ties and to provide an unobtrusive, clean cutoff point.

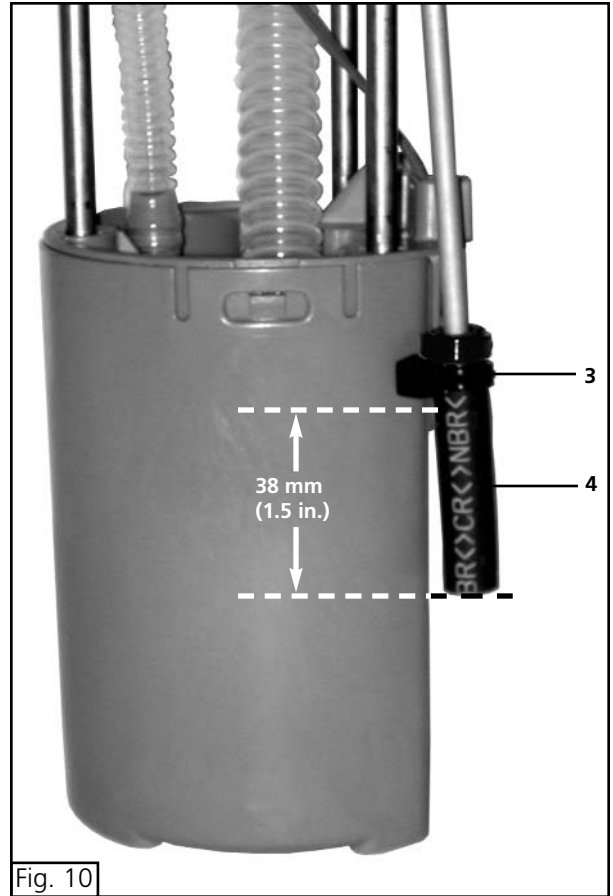

Item 3:

- Keep nylon cable tie head tucked in beside sender unit reservoir.

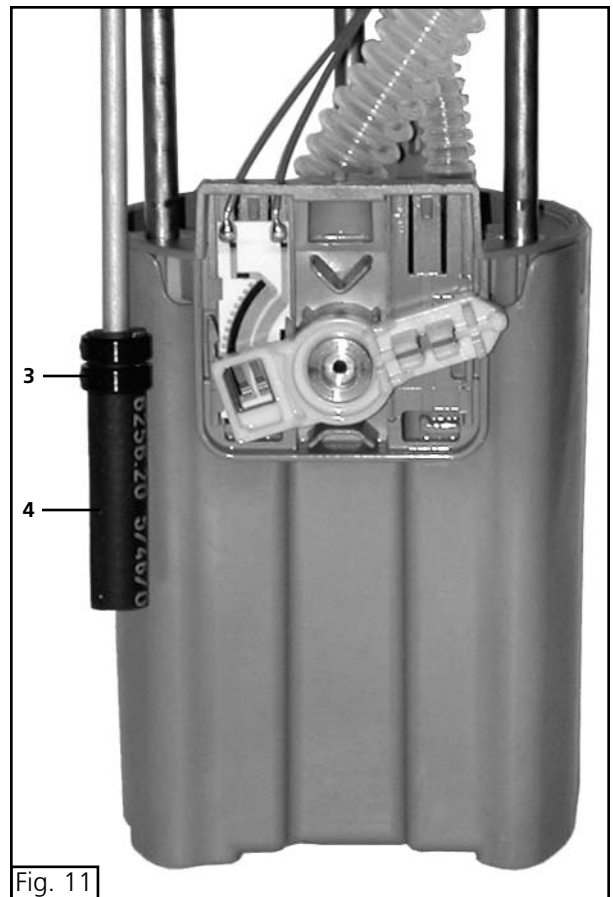

- Reinstall fuel sender unit. Refer to vehicle manufacturer's service instructions.

Item 2 and 3:

- Place one fuel line clamp over end of rubber fuel line coupler.
- Lubricate inside of rubber fuel line coupler with silicone spray lubricant or equivalent.

Item 1, 2 and 3:

- Push fuel line coupler onto standpipe outlet fully.
- Tighten clamp fully and torque to 1.0 - 1.4 Nm.

Item 3, 4 and 5:

- Place fuel line clamp over fuel line end of rubber coupler.
- Push Mecanyl fuel line fully into coupler until butted against standpipe outlet.
- Tighten clamp fully and torque to 1.0 - 1.4 Nm.

ATTENTION!

Fuel line clamps MUST be positioned as shown in Figure 12.

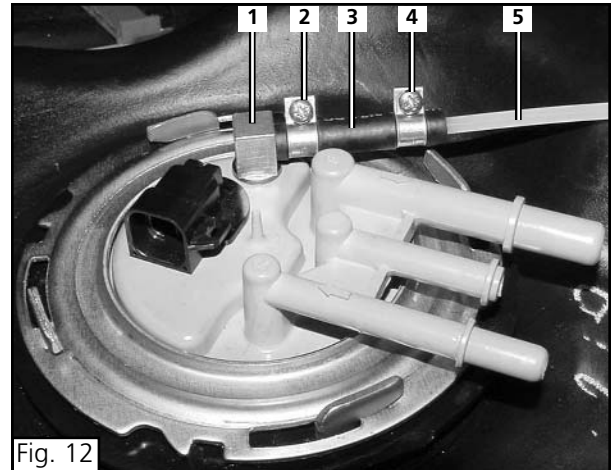

Fig. 12

Item 1 and 2:

- Connect fuel lines. Refer to vehicle manufacturer's service instructions if necessary.

Item 3:

- Connect wiring harness. Refer to vehicle manufacturer's service instructions if necessary.

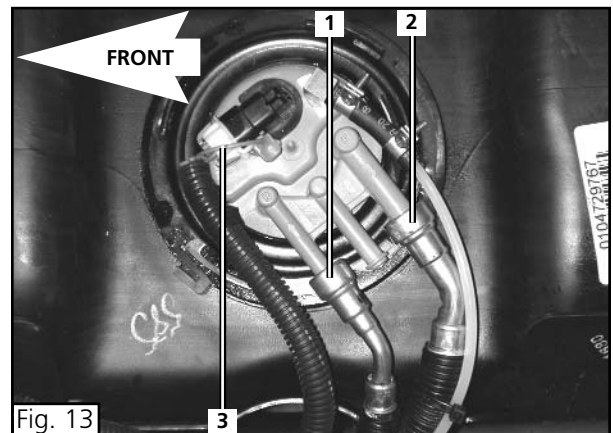

Fig. 13

CAUTION!

Mecanyl fuel line must be secured in a manner that prevents damage by sharp edges, abrasion, moving components and excessive heat. The following figures illustrate recommended tie points where fuel line should be secured with cable ties and/or existing vehicle components.

Item 1 and 2:

- Route Mecanyl fuel line along existing vehicle fuel lines as shown.
- Secure fuel line to existing vehicle fuel lines with nylon cable tie at the location shown using a cable tie gun.

ATTENTION!

A cable tie gun is recommended for applying nylon cable ties ensuring proper tensioning of ties and to provide an unobtrusive, clean cutoff point.

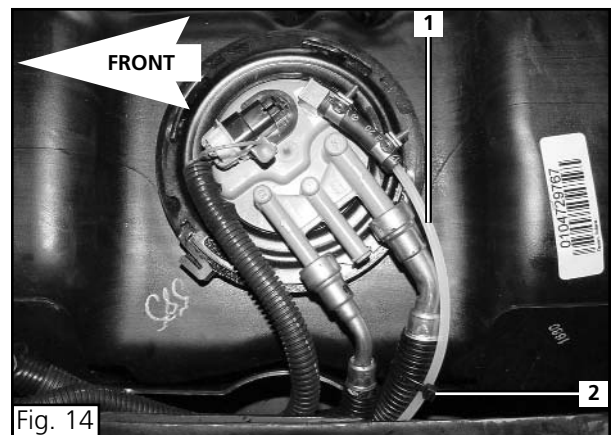
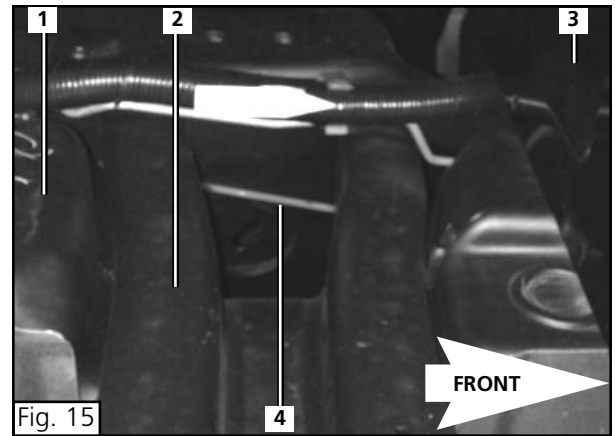

Fig. 14

Legend for Figure 15

- 1 Forward fuel tank
 - 2 Cross-member (Behind cab, over-top of forward fuel tank)
 - 3 Rear panel of cab
 - 4 Mecanyl fuel line
- Routing Mecanyl fuel line (4) between left side of fuel tank (1) and inner left frame rail forward as shown.



Legend for Figure 16

- 1 Fuel oil cooler
 - 2 Cross-member (Ahead of fuel oil cooler)
 - 3 Nylon cable tie
 - 4 Mecanyl fuel line
 - 5 Vehicle fuel lines
- Continue routing Mecanyl fuel line (4) along existing vehicle fuel lines (5) as shown.
- Secure fuel line to vehicle fuel line with nylon cable ties where possible.

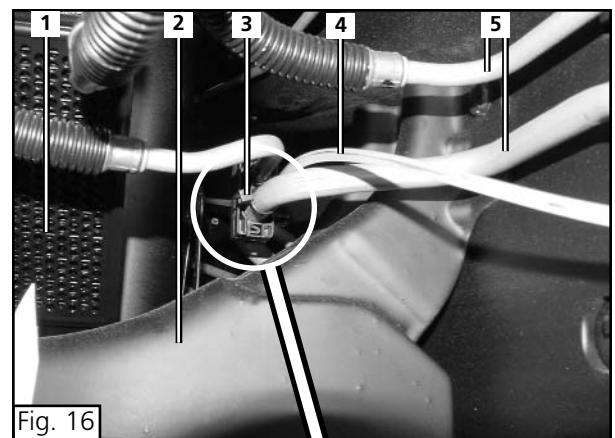

ATTENTION!

A cable tie gun is recommended for applying nylon cable ties ensuring proper tensioning of ties and to provide an unobtrusive, clean cutoff point.

NOTE:

Routing of the fuel line will be completed after installation of the fuel pump (see next page).

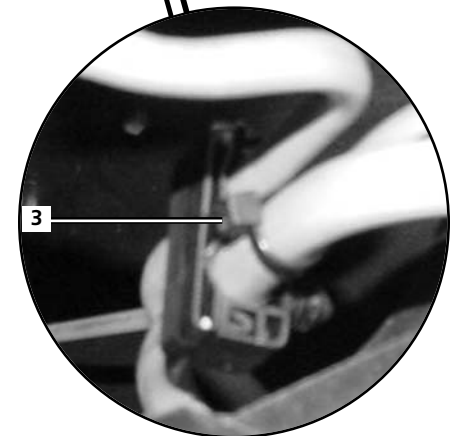

Fuel Metering Pump

General Information

The fuel pump is located inside of the left frame rail forward of the fuel tank. The pump is mounted parallel to and under the vehicle fuel lines.

Item 1 and 2:

- Mount fuel pump in mid section of left frame rail utilizing existing hole in frame.
- Refer to Figure 18 for fastening sequence.
- Torque cap screw and nut to 10 - 10.5 Nm.

Legend for Figure 18

- 1 P-clip (Fuel pump retaining)
- 2 Vehicle frame rail (left)
- 3 Fender Washer - M6
- 4 Cap screw - M6x20
- 5 Flanged nut - M6

ATTENTION!

Always cut Mecanyl fuel line with a sharp razor knife or razor edged cutter. DO NOT cut with side cutters, scissors or similar tools as doing so will cause a restriction inside the fuel line.

Item 1, 2 and 3:

- Route fuel line to fuel pump inlet.
- Cut fuel line to length.
- Connect fuel line to pump using the same procedure used when connecting to fuel standpipe.

NOTE:

The fuel line for the outlet side of the pump and the electrical cable have been installed and routed prior to the installation of the fuel pump.
To complete the installation, connect the outlet side fuel line and electrical connector.

Item 4, 5 and 6:

- Connect outlet side fuel line to pump outlet using the same procedure as the inlet side.

Item 7:

- Connect electrical cable to pump. Connector is fully seated when audible click is heard.

This concludes the installation of the fuel standpipe, fuel line, and fuel metering pump.

As a last step, check over the installation for loose lines, clamps and fasteners. Ensure fuel line is properly routed and secured against damage.

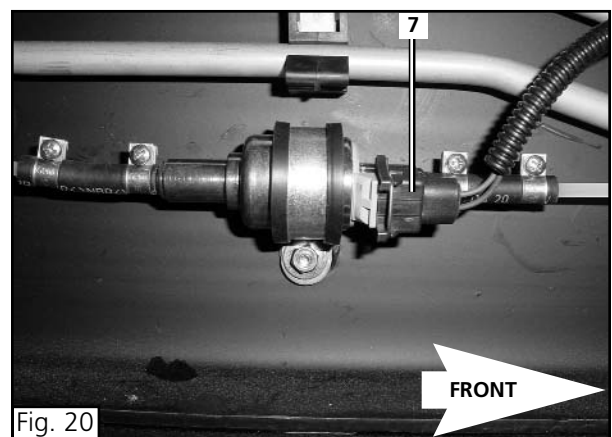
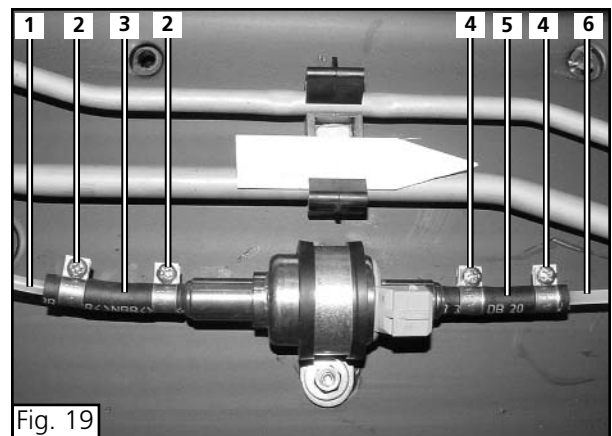
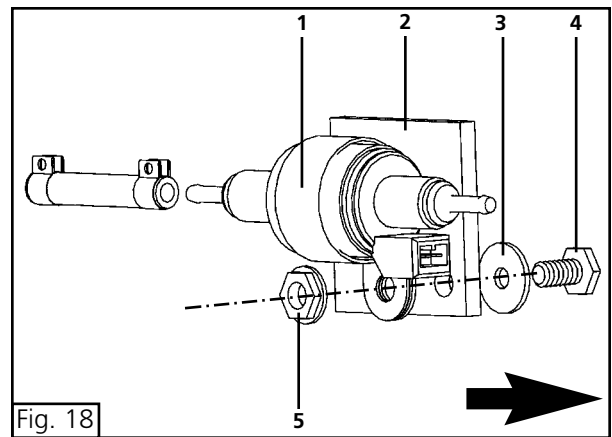
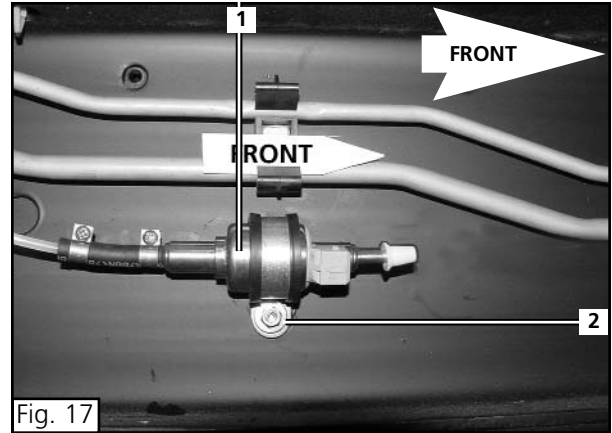



Org. 06/2003

Rev. 07/2003

P/N GM 3500 HD Military (Fuel Section)

Webasto Product N.A., Inc.

Technical Assistance Hotline

USA: (800) 555-4518

Canada: (800) 667-8900

www.webasto.us

www.techwebasto.com